

IntesisBox[®]



General catalogue 2013

KNX · MODBUS · BACNET · LONWORKS · ENOCEAN · ASCII · OPC SERVER

ENGLISH

your partner for **systems integration**

Intesis



General catalogue 2013

KNX · MODBUS · BACNET · LONWORKS · ENOCEAN · ASCII · OPC SERVER

Intesis Software S.L.

C/ Milà i Fontanals, 1 bis 1º
08700 Igualada · Barcelona · Spain

Tel. +34 93 804 71 34

Fax +34 93 804 71 35

info@intesis.com



Intesis Software is a company focused in solutions for systems integration for control, supervision and management of buildings. Our customers: manufacturers, control companies, integrators... They trust our products so to provide their equipment with the most advanced control and management features for the end user.

More than a decade of experience

Intesis Software S.L. was established in the year 2000. From the beginning it had the most important control companies in Spain among their clients. After 13 years, Intesis distributes its products and solutions to more than 80 countries worldwide and has a constantly growing distribution network. Main multinational companies in technical equipment for buildings trust our devices. Our challenge is the continuous innovation and technical development of new products, in order to provide our customers with the best integration solution.

IntesisBox®

The most advanced communication gateway solution for different system integration: KNX/EIB, LonWorks, ModBus, BACnet, EnOcean, M-Bus, ASCII, OPC and other proprietary protocols.



Houseinhand is an application for iPhone, iPad and iPod Touch that allows controlling the home in a very fast and intuitive way, managing and displaying the status of lights, blinds, thermostats..., all in real time. Houseinhand connects directly to the KNX installation via any KNX IP router. Houseinhand is continuously adding support for different devices with free updates. Downloadable from the App Store, install and try it for free in few steps. More info at www.houseinhand.com.

IntesisHome®

IntesisHome is the most advanced solution allowing the user to control their climate system from anywhere. Customers can use an iPad, iPhone, any Android device or simply a PC with Internet access, to use IntesisHome to control their heat pump or air conditioner from anywhere at the touch of a button. More info at www.intesishome.com.

OEM Products

We offer all our Know-how for the development of custom solutions for all kind of manufacturers of technical equipment for buildings. We can quickly enable your equipment with KNX/EIB, LonWorks, ModBus, BACnet, EnOcean, M-Bus, ASCII or OPCServer connectivity, reaching a reliable and quality product.

KNX gateways

ME-AC-KNX-1-V2. Integration of Mitsubishi Electric Air Conditioners, Mr. Slim and Domestic Series, in KNX systems	8
ME-AC-KNX-1i. Integration of Mitsubishi Electric Air Conditioners, Mr. Slim and Domestic Series, in KNX systems, with 4 free-use binary inputs.	9
ME-AC-KNX-15 / ME-AC-KNX-100. Integration of Mitsubishi Electric Air Conditioning units in KNX systems using G-50A, GB-50A or AG-150A	10
DK-AC-KNX-1. Integration of DAIKIN Air Conditioners, Domestic lines, in KNX systems.	11
DK-AC-KNX-1i. Integration of DAIKIN Air Conditioners, Domestic lines, in KNX systems, with 4 free-use binary inputs.	12
DK-RC-KNX-1. Integration of DAIKIN Air Conditioners, VRV and SKY Air lines, in KNX systems	13
MH-RC-KNX-1i. Integration of Mitsubishi Heavy Industries Air Conditioners, FD, KX6, KXR6 Series, in KNX systems, with 4 free-use binary inputs.	14
MH-AC-KNX-48 / MH-AC-KNX-128. Integration of Mitsubishi Heavy Industries Air Conditioning, VRF systems Superlink I & II, in KNX systems.	15
NEW FJ-RC-KNX-1i. Integration of Fujitsu Air Conditioners, RAC and VRF lines, in KNX systems, with 4 free-use binary inputs	16
NEW HI-AW-KNX-1. Integration of Hitachi Air-to-Water units, Yutaki series, in KNX systems.	17
PA-AC-KNX-1i. Integration of Panasonic Air Conditioners, Etherea MKE and NKE Series, in KNX systems, with 4 free-use binary inputs.	18
PA-RC-KNX-1i. Integration of Panasonic Air Conditioners, FS and FSM Series, in KNX systems, with 4 free-use binary inputs.	19
NEW PA-RC2-KNX-1i. Integration of Panasonic Air Conditioners, FS and FSM series, in KNX systems, with 4 free-use binary inputs.	20
NEW PA-AC-KNX-64/128. Integration of Panasonic Air Conditioners, ECOi and PACi series, in KNX systems.	21
AK-AC-KNX-4 / AK-AC-KNX-8 / AK-AC-KNX-16 / AK-AC-KNX-64. Integration of Arçelik Air Conditioning units in KNX systems.	22
LG-AC-KNX-4 / LG-AC-KNX-8 / LG-AC-KNX-16 / LG-AC-KNX-64. Integration of LG Air Conditioning units in KNX systems.	23
SM-AC-KNX-4 / SM-AC-KNX-8 / SM-AC-KNX-16 / SM-AC-KNX-64 / SM-AC-KNX-128. Integration of SAMSUNG Air Conditioning units in KNX systems	24
IBOX-KNX-AIRZONE. Integration of AIRZONE zoning systems in KNX systems	25
IBOX-KNX-LON. Integration of any LON device in KNX systems	26
IBOX-KNX-MBRTU / IBOX-KNX-MBTCP. Integration of any ModBus device in KNX systems	27
IBOX-KNX-BAC. Integration of any BACnet/IP device in KNX systems	28
IBOX-KNX-DSC4020. Integration of DSC MAXSYS PC4020 intrusion detection panel in KNX systems	29
IBOX-KNX-ENO-A1 / IBOX-KNX-ENO-A1C. Integration of any EnOcean device in KNX systems	30

MODBUS gateways

ME-AC-MBS-1 / ME-AC-MBS-1-2I10. Integration of Mitsubishi Electric Air Conditioners, Mr. Slim and Domestic Series, in MODBUS systems	34
ME-AC-MBS-50 / ME-AC-MBS-100. Integration of Mitsubishi Electric Air Conditioning units in MODBUS systems using G-50A, GB-50A or AG-150A	35
MH-RC-MBS-1. Integration of Mitsubishi Heavy Industries Air Conditioners, FD, KX6, KXR6 Series, in MODBUS systems	36
MH-AC-MBS-48 / MH-AC-MBS-128. Integration of Mitsubishi Heavy Industries Air Conditioning, VRF systems Superlink I & II, in MODBUS systems	37
DK-AC-MBS-1. Integration of DAIKIN Air Conditioners, Domestic series, in MODBUS systems	38
DK-RC-MBS-1. Integration of DAIKIN Air Conditioners, VRV and SKY Air series, in MODBUS systems	39
SM-AC-MBS-4 / SM-AC-MBS-8 / SM-AC-MBS-32 / SM-AC-MBS-64 / SM-AC-MBS-128. Integration of SAMSUNG Air Conditioning units in MODBUS systems	40
FJ-RC-MBS-1. Integration of FUJITSU Air Conditioners, Commercial series, in MODBUS systems	41
NEW PA-RC2-MBS-1. Integration of Panasonic Air Conditioners, FS and FSM series, in MODBUS systems	42
NEW PA-AW-MBS-1. Integration of Panasonic Air-to-Water units, Aquarea series, in MODBUS systems	43
IBOX-MBS-KNX. Integration of any KNX device in MODBUS systems	44
IBOX-MBS-MBUS. Integration of any M-BUS device in MODBUS systems	45
IBOX-MBS-BAC. Integration of any BACnet/IP device in MODBUS systems	46
IBOX-MBS-BACMSTP. Integration of any BACnet/MSTP device in MODBUS systems	47
IBOX-MBS-LON. Integration of any LON device in MODBUS systems	48

IBOX-MBS-DALI. Integration of DALI ballasts in MODBUS systems	49
IBOX-MBS-ATERSA. Integration of ATERSA inverters (photovoltaic) in MODBUS systems	50
IBOX-MBS-FIDELIO_IP. Integration of MICROS FIDELIO hotel management in MODBUS systems	51
IBOX-MBS-TCP2RTU. Integration of any Modbus RTU Slave device in Modbus TCP	52
IBOX-MBS-4SLAVE. Sharing data of up to 4 Modbus Master devices between themselves	53
IBOX-MBS for FIRE AND SECURITY SYSTEMS. Integration of fire and security control panels in MODBUS systems	54

BACNET gateways

NEW PA-AC-BAC-64/128. Integration of Panasonic Air Conditioners, ECOi and PACi series, in BACnet/IP systems	58
IBOX-BAC-KNX. Integration of any KNX device in BACnet/IP systems	59
IBOX-BAC-MBRTU / IBOX-BAC-MBTCP. Integration of any ModBus device in BACnet/IP systems	60
IBOX-BAC-LON. Integration of any LonWorks device in BACnet/IP systems	61
IBOX-BAC-FIDELIO_IP. Integration of MICROS FIDELIO hotel management in BACnet/IP systems	62
IBOX-BAC-MBUS. Integration of any M-BUS device in BACnet/IP systems	63
IBOX-BAC-DALI. Integration of DALI ballasts in BACnet/IP systems	64
IBOX-BAC-SUNWAYS. Integration of SUNWAYS inverters (photovoltaic) in BACnet/IP systems	65
IBOX-BAC-NID3000. Integration of Notifier ID series fire panels in BACnet/IP systems	66

LON gateways

ME-AC-LON-1. Integration of Mitsubishi Electric Air Conditioners, Mr. Slim and Domestic Series, in LON systems	70
IBOX-LON-PANURBAN. Integration of Panasonic Air Conditioning units in LON systems	71
IBOX-LON-KNX. Integration of any KNX device in LON systems	72

ENOCEAN gateways

ME-AC-ENO-1 / ME-AC-ENO-1C. Integration of Mitsubishi Electric Air Conditioners, Mr. Slim and Domestic Series, in EnOcean systems	76
MH-RC-ENO-1i / MH-RC-ENO-1iC. Integration of Mitsubishi Heavy Industries Air Conditioners, FD, KX6, KXR6 and HyperMulti Series, in EnOcean systems, with 4 free-use binary inputs.	77
DK-AC-ENO-1 / DK-AC-ENO-1C. Integration of DAIKIN Air Conditioners, Domestic lines, in EnOcean systems	78
DK-RC-ENO-1i / DK-RC-ENO-1iC. Integration of DAIKIN Air Conditioners, VRV and SKY Air lines, in EnOcean systems, with 4 free-use binary inputs.	79
PA-AC-ENO-1i / PA-AC-ENO-1iC. Integration of Panasonic Air Conditioners, Etherea MKE & NKE Series, in EnOcean systems, with 4 free-use binary inputs.	80
USB-ENO / USB-ENO-C. Integration of any EnOcean device in your USB enabled controller or PC software	81
USB-ENO-ASCII / USB-ENO-ASCII-C. Integration of any IntesisBox® EnOcean Gateway for Air Conditioners in your USB enabled controller or PC software using simple text (ASCII) messages	82
USB-ENO-ASCII-U / USB-ENO-ASCII-U-C. Integration of any EnOcean device in your USB enabled controller or PC software using simple text (ASCII) messages	83
NEW IS-TK04. Room temperature sensor to control the EnOcean Air conditioner gateways as well as other climate devices.	84
NEW IS-TK65. EnOcean outdoor sensor to provide outdoor temperature to EnOcean devices.	84

ASCII gateways

IBOX-ASCII-KNX. Control of any KNX device using simple text (ASCII) messages	87
IBOX-ASCII-LON. Control of any LON device using simple text (ASCII) messages	88
IBOX-ASCII-BAC. Control of any BACnet/IP device using simple text (ASCII) messages	89

OPC SERVERS

IS-OPC-NID3K. OPC server for Integration of Notifier ID series fire panels in ID2NET network	91
IS-OPC-ESSER. OPC server for Integration of Esser 8xxx/IQ8 fire panels	91



KNIX

IntesisBox

products for KNX systems



KNX is the world's only open Standard for the control in both commercial and residential buildings. KNX is approved as an International Standard (ISO/IEC 14543-3) as well as an European Standard (CENELEC EN 50090 and CEN EN 13321-1) and Chinese Standard (GB/Z 20965). KNX products made by different manufacturers can be combined. **This standard is based upon more than 20 years of experience in the market**, amongst others with predecessor systems to KNX: EIB, EHS and BatiBUS. Via the KNX medium to which all bus devices are connected (twisted pair, radio frequency, power line or IP/Ethernet), they are able to exchange information. Bus devices can either be sensors or actuators needed for the control of building management equipment such as: lighting, blinds / shutters, security systems, energy management, heating, ventilation and air-conditioning systems, signalling and monitoring systems, interfaces to service and building control systems, remote control, metering, audio / video control, white goods, etc. Several millions of successful KNX installations can be found not only all over Europe but also in the Far East, North and South America. Over 100 KNX member companies worldwide offer almost 7.000 KNX certified product groups in their catalogues, from different application domains.

Source: KNX Association. For further information visit www.knx.org

KNX

IntesisBox® KNX gateways for Air Conditioners

Specially designed, in collaboration with several manufacturers like Mitsubishi Electric, Daikin, Panasonic, LG, Samsung, Mitsubishi Heavy Industries... to allow supervision and bidirectional control of all the parameters and functionality of Air conditioners and zonification systems from KNX installations.

- Easy installation
- Great integration flexibility, with direct configuration from the ETS or using the Intesis LinkBoxEIB software
- Possibility to use KNX temperature sensor to control the Air Conditioner
- Advanced functionality for high degree of comfort and energy savings.

IntesisBox KNX gateways for multi-protocol integration

IntesisBox® IBOX-KNX gateways have been specially designed to allow supervision and bidirectional control of all the parameters and functionality of LonWorks®, Modbus, BACnet/IP or EnOcean devices from KNX installations.

- Direct connection to field bus (no additional adapters required) KNX/TP, LON TP/FT10, RS485, RS232, Ethernet, wireless.
- Great integration flexibility

Easy integration of VRF air conditioning systems and Chillers equipped with LON, BACnet, or Modbus gateway, with templates available in LinkBox software for different integrations, i.e. Daikin, Mitsubishi Electric, Sanyo, Fujitsu, LG, Toshiba, Ciatesa, Hitecsa, Lennox, Carrier, etc. Integrate almost anything in your KNX projects: meters, PLC's, AC, Chillers, HMI, card readers, thermostats, room controllers.

ME-AC-KNX-1-V2

IntesisBox® ME-AC-KNX-1-V2 allows monitoring and control, fully bi-directionally, of all the operational parameters of Mitsubishi Electric air conditioners from KNX installations.

Compatible with Domestic and Mr. Slim Series manufactured by Mitsubishi Electric.



Specifications

- Bidirectional: Monitoring and Control
- Configuration from ETS
- Direct connection to KNX TP bus and to the AC indoor unit
- No external power supply required
- Small size (WxHxD): 59 x 36 x 21 mm.

Main features

- Easy installation, even inside the air conditioning indoor unit. Cable to connect to CN105 or CN92 connector is supplied.
- Great integration flexibility. Configured directly from the ETS.
- Special communication objects for increasing comfort and energy savings: Open window, Working hours counter, Save /execute scenes, Enable/Disable device, Enable/disable remote controller,...
- "Virtual temperature" functionality. Useful when an external ambient temperature reference is required (KNX sensor or thermostat) to control the AC, or when the heating and AC unit need to be controlled from the same KNX thermostat.
- Simultaneous control from KNX and from the IR controller of the Air Conditioner.

Info

Datasheet: http://www.intesis.com/pdf/IntesisBox_ME-AC-KNX-1_datasheet_eng.pdf

Compatibility list: http://www.intesis.com/pdf/IntesisBox_ME-AC-xxx-1_AC_Compatibility.pdf

ME-AC-KNX-1i

IntesisBox® ME-AC-KNX-1i allows monitoring and control, fully bi-directionally, of all the operational parameters of Mitsubishi Electric air conditioners from KNX installations.

Compatible with Domestic and Mr. Slim Series manufactured by Mitsubishi Electric. 4 free-use binary inputs.

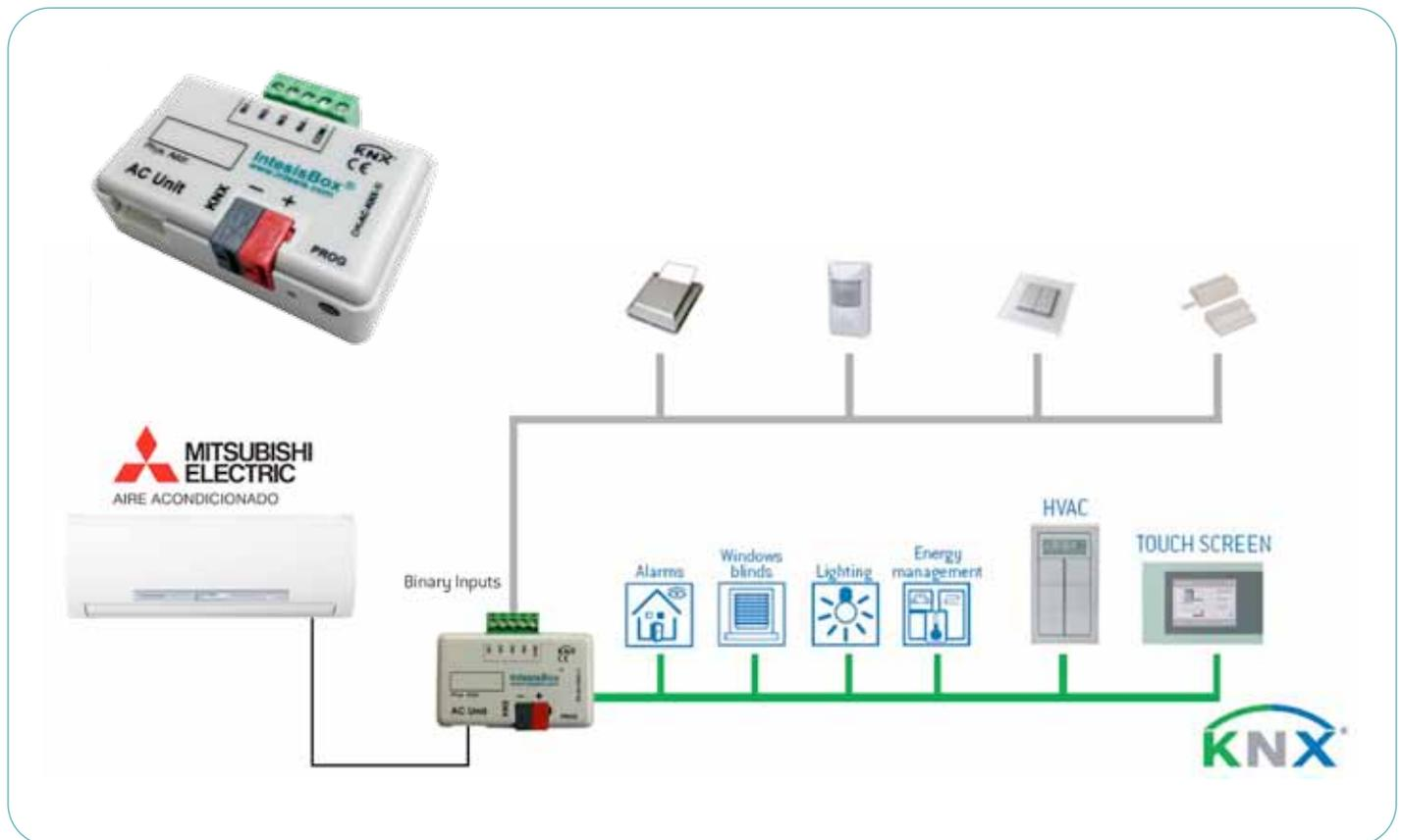

Specifications

- Bidirectional: Monitoring and Control
- Configuration from ETS
- Direct connection to KNX bus and to the AC indoor unit
- 4 binary inputs for potential-free contacts
- Allows use of KNX temperature sensor
- No external power supply required
- Small size (WxHxD): 59 x 45 x 21 mm.

Main features

- Easy installation inside the air conditioning indoor unit. Cable to connect to CN105 or CN92 connector supplied.
- Great integration flexibility. Configured directly from the ETS.
- Special communication objects for increasing comfort and energy savings: Open window, Working hours counter, Save /execute scenes, Enable/Disable device, Enable/disable remote controller,...
- Ambient temperature functionality. Useful when an external ambient temperature reference is required (KNX sensor or thermostat) or when the heating and AC unit need to be controlled from the same KNX thermostat.
- Simultaneous control from KNX and the Air Conditioner IR handset.

Info

Datasheet: http://www.intesis.com/pdf/IntesisBox_ME-AC-KNX-1i_datasheet_eng.pdf

Compatibility list: http://www.intesis.com/pdf/IntesisBox_ME-AC-xxx-1_AC_Compatibility.pdf

ME-AC-KNX-15 / ME-AC-KNX-100

IntesisBox® ME-AC-KNX-15 / 100 gateways have been specially designed, in collaboration with Mitsubishi Electric, to allow monitoring and bidirectional control of all the parameters and functionality of Mitsubishi Electric air conditioners using G-50A, GB-50A or AG-150A controllers from KNX installations.



AG-150A



G-50A



GB-50A



GB-50ADA



Compatible with all Mitsubishi Electric air conditioning units connected to centralized controls. The AG-150A must have the FGWEBASIC function (Web basic package).

Specifications

- Bidirectional: Monitoring and Control
- Robust and reliable hardware
- Direct connection to KNX bus
- Independent management of communications
- Power supply: 9 to 24Vdc or 24Vac
- Standard DIN-Rail 6 modules enclosure

Models available

- ME-AC-KNX-15 (Maximum 15 group of indoor units and 1 G-50A / GB50A / AG-150A / GB-50ADA centralized control)
- ME-AC-KNX-100 (Maximum 100 group of indoor units and 2 G-50A / GB-50A / AG-150A / GB-50ADA centralized controls)

Main features

- Communication through Ethernet to centralized controls G-50A / GB-50A / AG-150A / GB-50ADA
- Great integration flexibility. Using the supplied software LinkBoxEIB, a complete set of communication objects can be accessed. Monitoring and control from basic parameters to a complete monitoring and control of the AC units is possible.
- Virtual temperature functionality. Useful when an external ambient temperature reference is required (KNX sensor or thermostat) or when the heating and AC unit need to be controlled from the same KNX thermostat.

Info

Datasheet: http://www.intesis.com/pdf/IntesisBox_KNX_ME_G50_datasheet_eng.pdf

DK-AC-KNX-1

IntesisBox® DK-AC-KNX-1 allows monitoring and control, fully bi-directionally, all the operational parameters of DAIKIN air conditioners from KNX installations. Compatible with Domestic Series manufactured by DAIKIN.

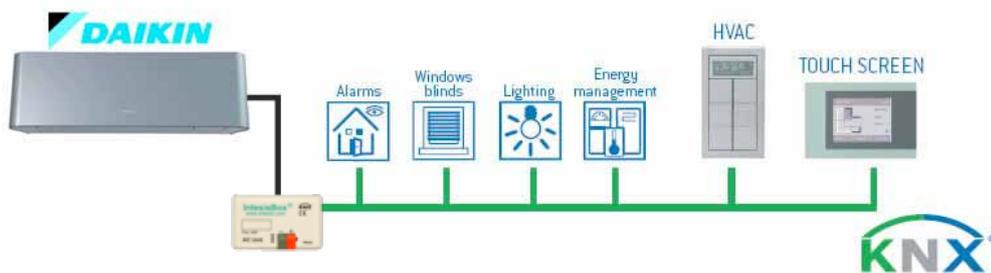

Specifications

- Bidirectional: Monitoring and Control
- Configuration from ETS
- Direct connection to KNX bus and to the AC indoor unit
- No external power supply required
- Small size (WxHxD): 59 x 36 x 21 mm

Main features

- Easy installation inside the AC indoor unit. Cable to connect to S21 connector supplied.
- Great integration flexibility. Configured directly from the ETS.
- Special communication objects for increasing comfort and energy savings: Open window, Working hours counter, Save /execute scenes, Enable/Disable device, Enable/disable remote controller,...
- Virtual temperature functionality. Useful when an external ambient temperature reference is required (KNX sensor or thermostat) or when the heating and AC unit need to be controlled from the same KNX thermostat.
- Simultaneous control from KNX and the Air Conditioner IR handset.

Info

Datasheet : http://www.intesis.com/pdf/IntesisBox_DK-AC-KNX-1_datasheet_eng.pdf

Compatibility list: http://www.intesis.com/pdf/IntesisBox_DK-AC-xxx-1_AC_Compatibility.pdf

DK-AC-KNX-1i

IntesisBox® DK-AC-KNX-1i allows monitoring and control, fully bi-directionally, of all the operational parameters of DAIKIN air conditioners from KNX installations. Compatible with Domestic Series manufactured by DAIKIN. 4 free-use binary inputs.

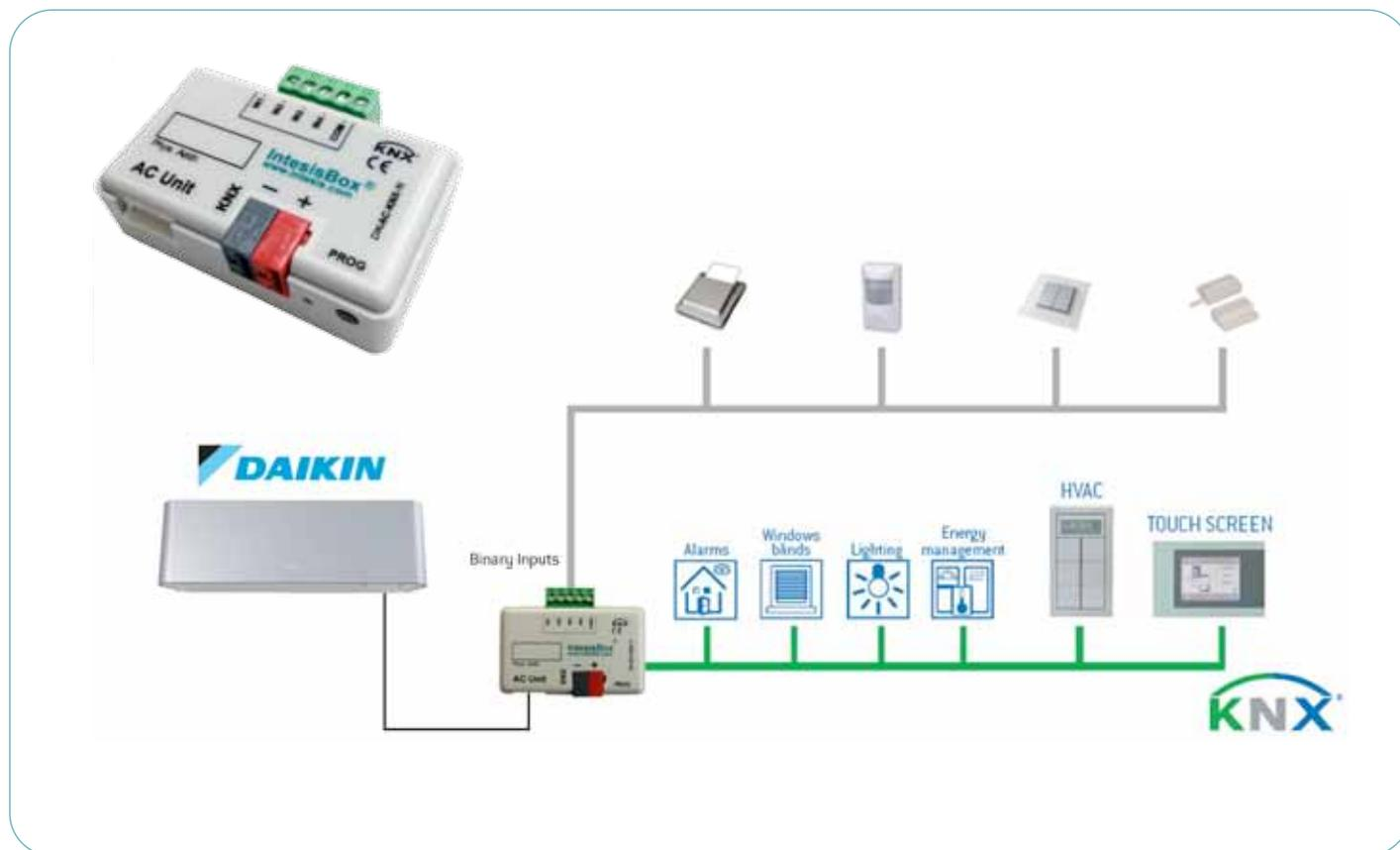

Specifications

- Bidirectional: Monitoring and Control
- Configuration from ETS
- 4 binary inputs for potential-free contacts
- Direct connection to KNX bus and to the AC indoor unit
- Allows use of a KNX temperature sensor
- No external power supply required
- Small size (WxHxD): 59 x 45 x 21 mm

Main features

- Easy installation inside the air conditioning indoor unit. Cable to connect to S21 connector supplied.
- Great integration flexibility. Configured directly from the ETS.
- Special communication objects for increasing comfort and energy savings: Open window, Working hours counter, Save /execute scenes, Enable/Disable device, Enable/disable remote controller,...
- Virtual temperature functionality. Useful when an external ambient temperature reference is required (KNX sensor or thermostat) or when the heating and AC unit need to be controlled from the same KNX thermostat.
- Simultaneous control from KNX and the Air Conditioner IR handset.

Info

Datasheet: http://www.intesis.com/pdf/IntesisBox_DK-AC-KNX-1i_datasheet_eng.pdf

Compatibility list: http://www.intesis.com/pdf/IntesisBox_DK-AC-xxx-1_AC_Compatibility.pdf

DK-RC-KNX-1

IntesisBox® DK-RC-KNX-1 gateway allows monitoring and bidirectional control of all the parameters and functionality of DAIKIN air conditioners from KNX installations. Compatible with SKY Air & VRV Series manufactured by DAIKIN.

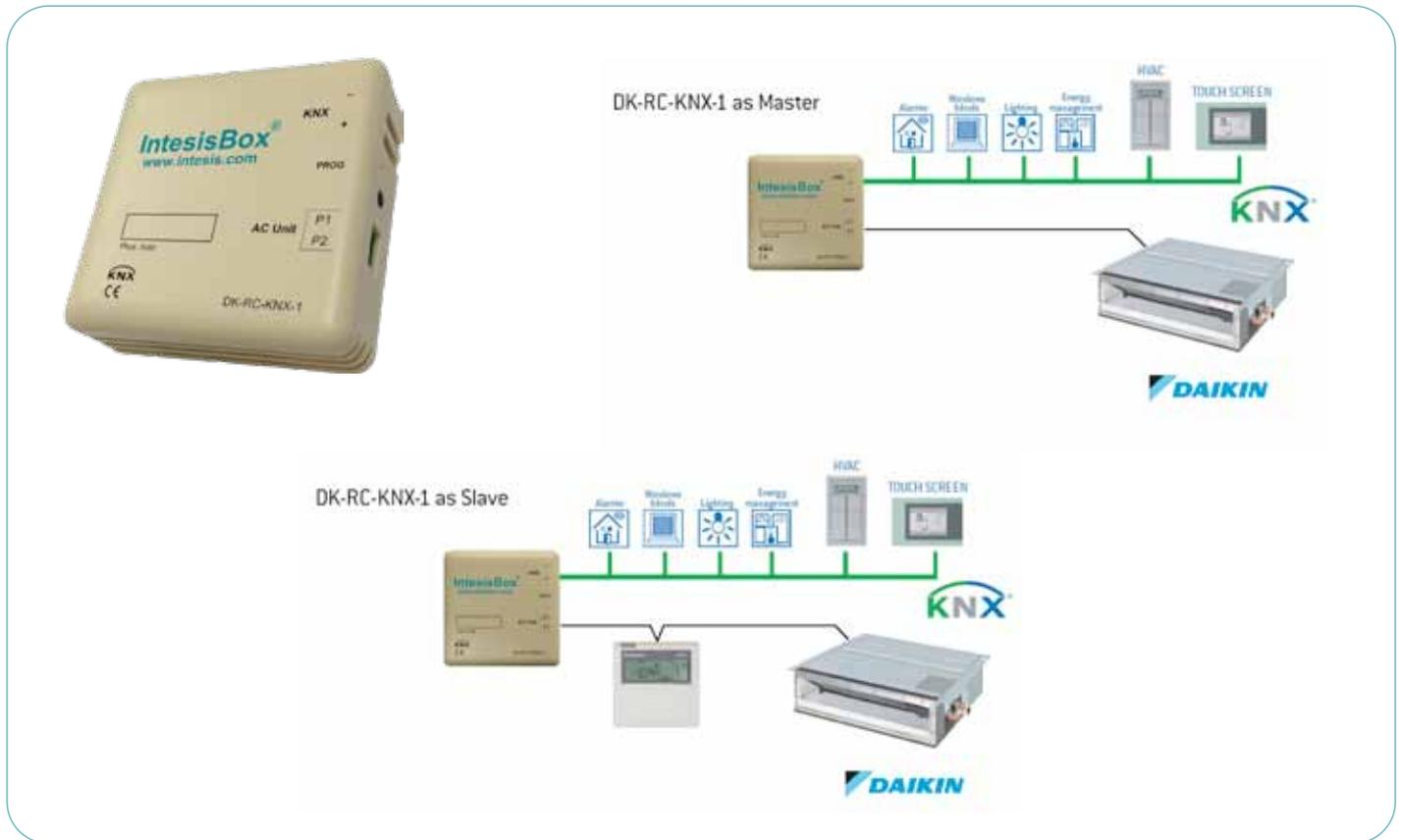

Specifications

- Bidirectional: Monitoring and Control
- Configuration from ETS
- Direct connection to KNX bus and to the AC indoor unit
- Connection type: 2 wires without polarity.
- Total maximum distance: 500 m.
- No external power supply required
- Small size (WxHxD): 71 x 71 x 27 mm

Main features

- Easy installation as Slave or Master in parallel with Daikin remote controllers.
- Great integration flexibility. Configured directly from the ETS.
- Special communication objects for increasing comfort and energy savings: Open window, Working hours counter, Save /execute scenes, Enable/Disable device, Enable/disable remote controller,...
- Virtual temperature functionality. Useful when an external ambient temperature reference is required (KNX sensor or thermostat) or when the heating and AC unit need to be controlled from the same KNX thermostat.
- Simultaneous control from KNX and the Air Conditioner Remote Controller.

Info

Datasheet: http://www.intesis.com/pdf/IntesisBox_DK-RC-KNX-1_datasheet_eng.pdf

Compatibility list: http://www.intesis.com/pdf/IntesisBox_DK-RC-xxx-1_AC_Compatibility.pdf

MH-RC-KNX-1i

IntesisBox® MH-RC-KNX-1i gateway allows monitoring and bidirectional control of all the parameters and functionality of Mitsubishi Heavy Industries air conditioners from KNX installations. Compatible with FD, KX6 and KXR6 Series manufactured by Mitsubishi Heavy Industries. 4 free-use binary inputs.

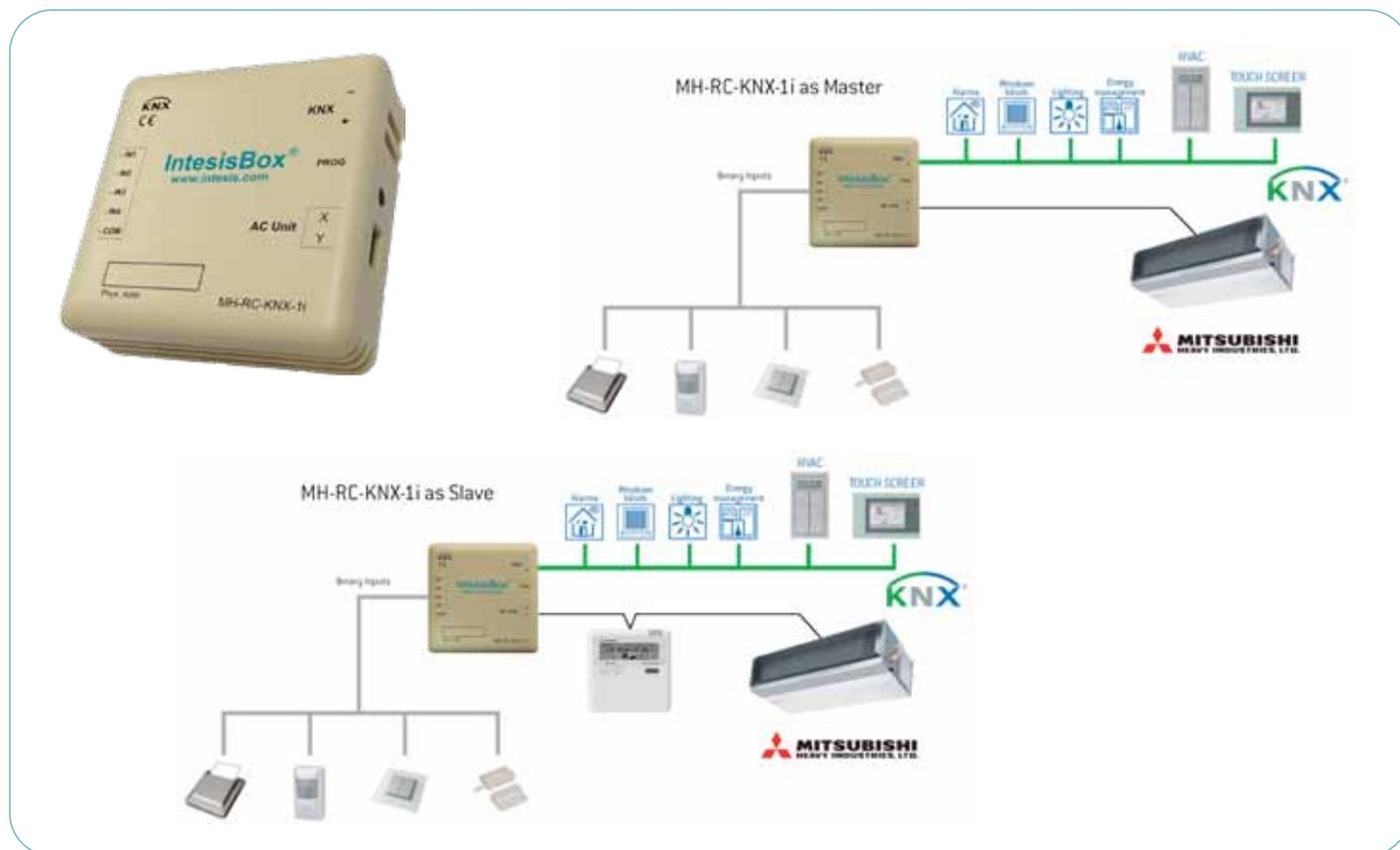

Specifications

- Bidirectional: Monitoring and Control
- Configuration from ETS
- Direct connection to KNX bus and to the AC indoor unit
- 4 binary inputs for potential-free contacts
- Connection type: 2 wires without polarity.
- Total maximum distance: 600 m.
- No external power supply required
- Small size (WxHxD): 71 x 71 x 27 mm

Main features

- Easy installation as Slave or Master in parallel with Mitsubishi Heavy Industries remote controllers.
- Great integration flexibility. Configured directly from the ETS.
- Special communication objects for increasing comfort and energy savings: Open window, Working hours counter, Save /execute scenes, Enable/Disable device, Enable/disable remote controller,...
- Virtual temperature functionality. Useful when an external ambient temperature reference is required (KNX sensor or thermostat) or when the heating and AC unit need to be controlled from the same KNX thermostat.
- Simultaneous control from KNX and the Mitsubishi Heavy Industries air conditioner Remote Controller.

Info

Datasheet: http://www.intesis.com/pdf/IntesisBox_MH-RC-KNX-1i_datasheet_eng.pdf

Compatibility list: http://www.intesis.com/pdf/IntesisBox_MH-RC-xxx-1_AC_Compatibility.pdf

MH-AC-KNX-48 / MH-AC-KNX-128

IntesisBox® MH-AC-KNX-48 / 128 gateways have been specially designed, in collaboration with Mitsubishi Heavy Industries, to allow Monitoring and bidirectional control of all the parameters and functionality of Mitsubishi Heavy Industries air conditioning, VRF Superlink I&II systems from KNX installations.

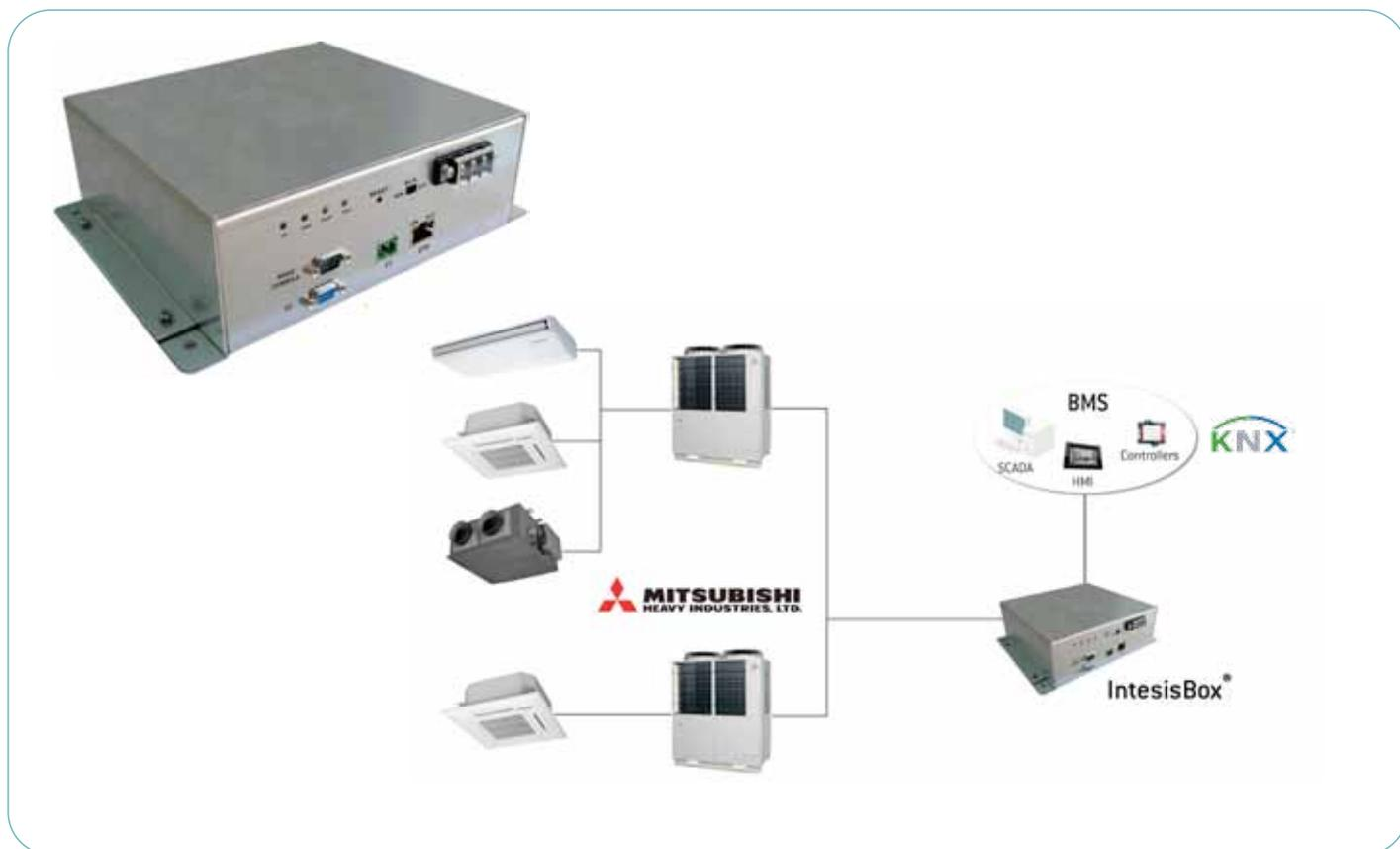

Specifications

- Bidirectional: Monitoring and Control
- Robust and reliable hardware
- Direct connection to KNX bus
- Direct connection to VRF bus
- Independent management of communications
- Power supply: 230 VAC
- Size (WxHxD): 215 x 170 x 65 mm

Models available

- MH-AC-KNX-48: supports up to 48 indoor units
- MH-AC-KNX-128: supports up to 128 indoor units

Info

Datasheet: http://www.intesis.com/pdf/IntesisBox_MH-AC-KNX-48-128_datasheet_eng.pdf

Compatibility list: http://www.intesis.com/pdf/IntesisBox_MH-AC-xxx-1_AC_Compatibility.pdf

Main features

- Compatible with all Mitsubishi Heavy Industries units connected to SuperLink Bus.
- Easy installation. Direct connection to SuperLink Bus.
- Great integration flexibility. Using the software LinkBoxEIB, a complete set of communication objects can be accessed.
- Advanced integration with air conditioner. Simultaneous control from KNX and the Mitsubishi Heavy Industries Remote controller.

FJ-RC-KNX-1i

IntesisBox® FJ-RC-KNX-1i gateway allows Monitoring and bidirectional control of all the parameters and functionality of Fujitsu air conditioners from KNX installations. Compatible with RAC and VRF indoor units

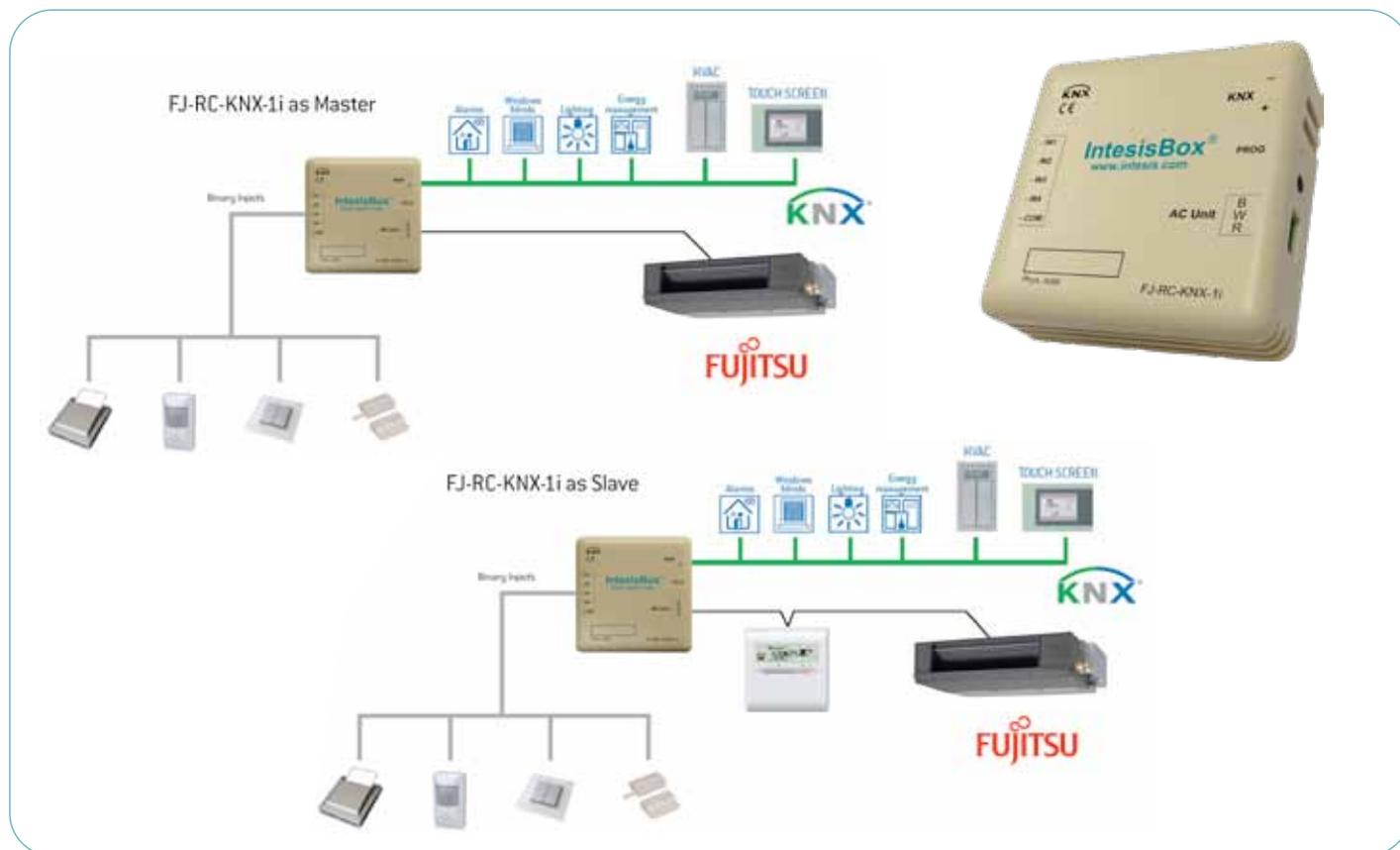

Specifications

- Bidirectional: Monitoring and Control
- Configuration from ETS
- Direct connection to KNX bus and to the AC indoor unit
- 4 binary inputs for potential-free contacts
- Connection type: 2 wires without polarity.
- Total maximum distance: 500 m.
- No external power supply required
- Small size (WxHxD): 71 x 71 x 27 mm

Main features

- Easy installation as Slave or Master in parallel with Fujitsu remote controllers.
- Great integration flexibility. Configured directly from the ETS.
- Special communication objects for increasing comfort and energy savings: Open window, Working hours counter, Save /execute scenes, Enable/Disable device, Enable/disable remote controller,...
- Simultaneous control from KNX and the Air Conditioner Remote Controller.

Info

Datasheet: http://www.intesis.com/pdf/IntesisBox_FJ-RC-KNX-1i_datasheet_eng.pdf

Compatibility list: http://www.intesis.com/pdf/IntesisBox_FJ-RC-xxx-1_AC_Compatibility.pdf

HI-AW-KNX-1

IntesisBox® HI-AW-KNX-1 gateway allows monitoring and bidirectional control of all the parameters and functionality of HITACHI Yutaki air to water units from KNX installations. Compatible with Yutaki and Yutaki S80 units.

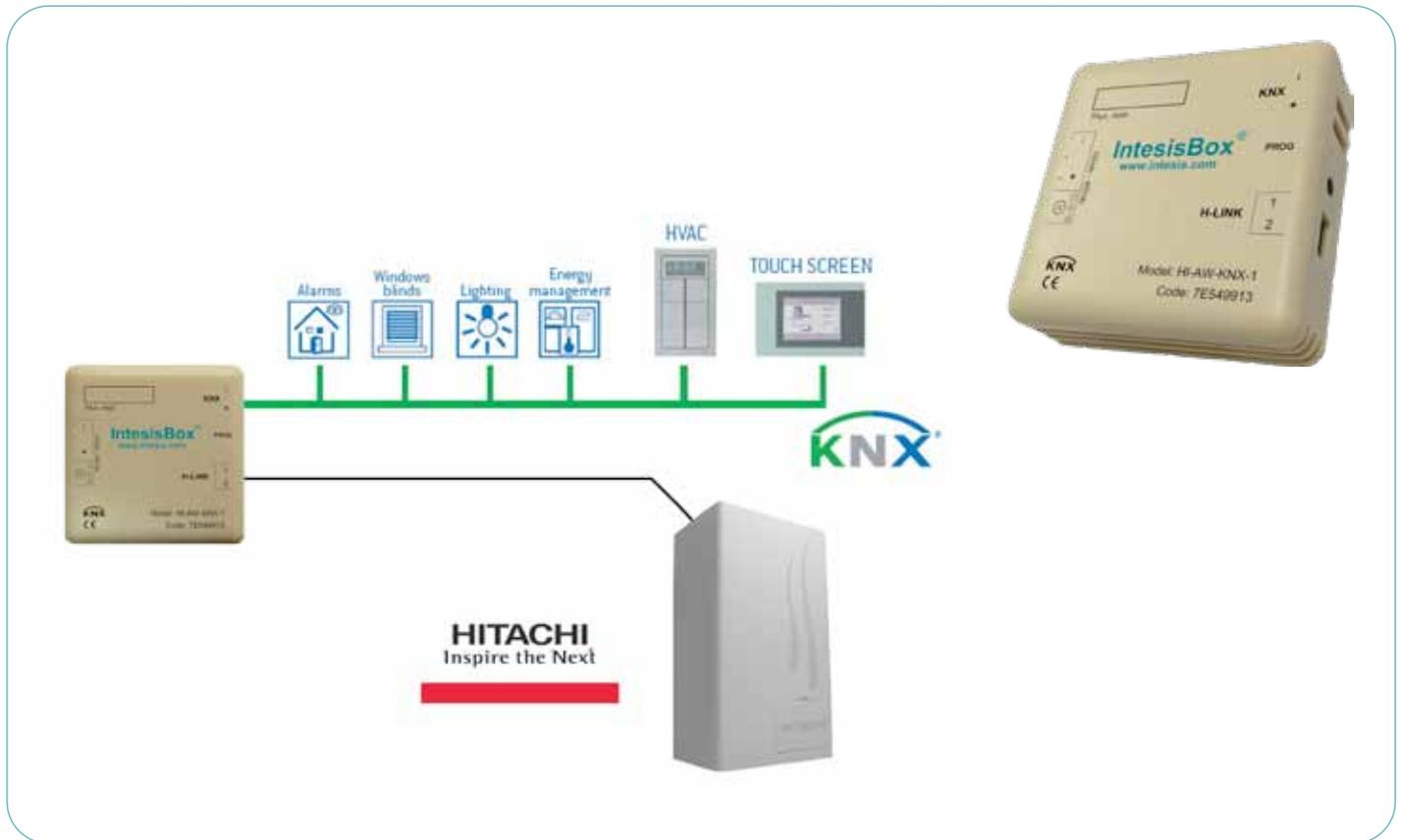

Specifications

- Bidirectional: Monitoring and Control
- Configuration from ETS
- Direct connection to KNX bus and to the H-Link bus
- Connection type: 2 wires without polarity
- Total maximum distance: 1000 m
- Power Supply: 10 to 40Vdc, 100mA
- Small size (WxHxD): 71 x 71 x 27 mm

Main features

- Easy installation. Direct connection to H-Link bus.
- Great integration flexibility. Configured directly from the ETS.
- Special communication objects for increasing comfort and energy savings.
- Ambient temperature functionality. Useful when an external ambient temperature reference is required (KNX sensor or thermostat) or when the heating and AC unit need to be controlled from the same KNX thermostat.
- Simultaneous control from KNX and the Hitachi remote controller.

Info

Datasheet: http://www.intesis.com/pdf/IntesisBox_HI-AW-KNX-1_datasheet_eng.pdf

PA-AC-KNX-1i

IntesisBox® PA-AC-KNX-1i allows monitoring and control, fully bi-directionally, all the operational parameters of PANASONIC air conditioners from KNX installations. Compatible with Ethearea MKE and NKE Series manufactured by PANASONIC. 4 free-use binary inputs.

KNX

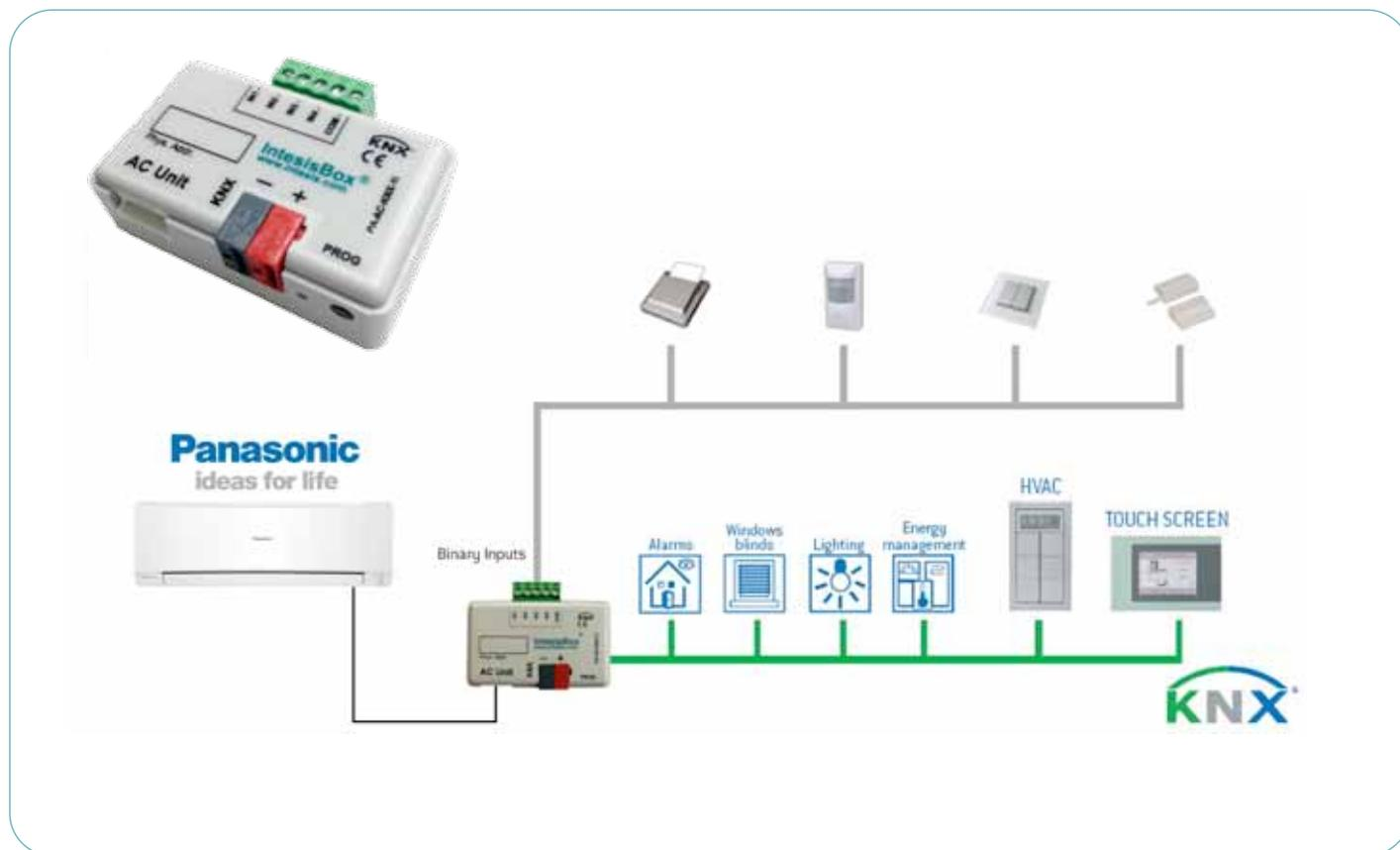

Specifications

- Bidirectional: Monitoring and Control
- Configuration from ETS
- Direct connection to KNX bus and to the AC indoor unit
- 4 binary inputs for potential-free contacts
- Use of KNX temperature sensor possible
- No external power supply required
- Small size (WxHxD): 59 x 45 x 21 mm

Main features

- Easy installation inside the AC indoor unit. Cable to connect to CN-CNT connector supplied.
- Great integration flexibility. Configured directly from the ETS.
- Special communication objects for increasing comfort and energy savings: Open window, Working hours counter, Save /execute scenes, Enable/Disable device, Enable/disable remote controller,...
- Virtual temperature functionality. Useful when an external ambient temperature reference is required (KNX sensor or thermostat) or when the heating and AC unit need to be controlled from the same KNX thermostat.
- Simultaneous control from KNX and the IR Air Conditioner handset.

Info

Datasheet: http://www.intesis.com/pdf/IntesisBox_PA-AC-KNX-1i_datasheet_eng.pdf

Compatibility list: http://www.intesis.com/pdf/IntesisBox_PA-AC-xxx-1_AC_Compatibility.pdf

PA-RC-KNX-1i

IntesisBox® PA-RC-KNX-1i gateway allows Monitoring and bidirectional control of all the parameters and functionality of PANASONIC air conditioners from KNX installations. Compatible with FS and FSM Series manufactured by PANASONIC. 4 free-use binary inputs.

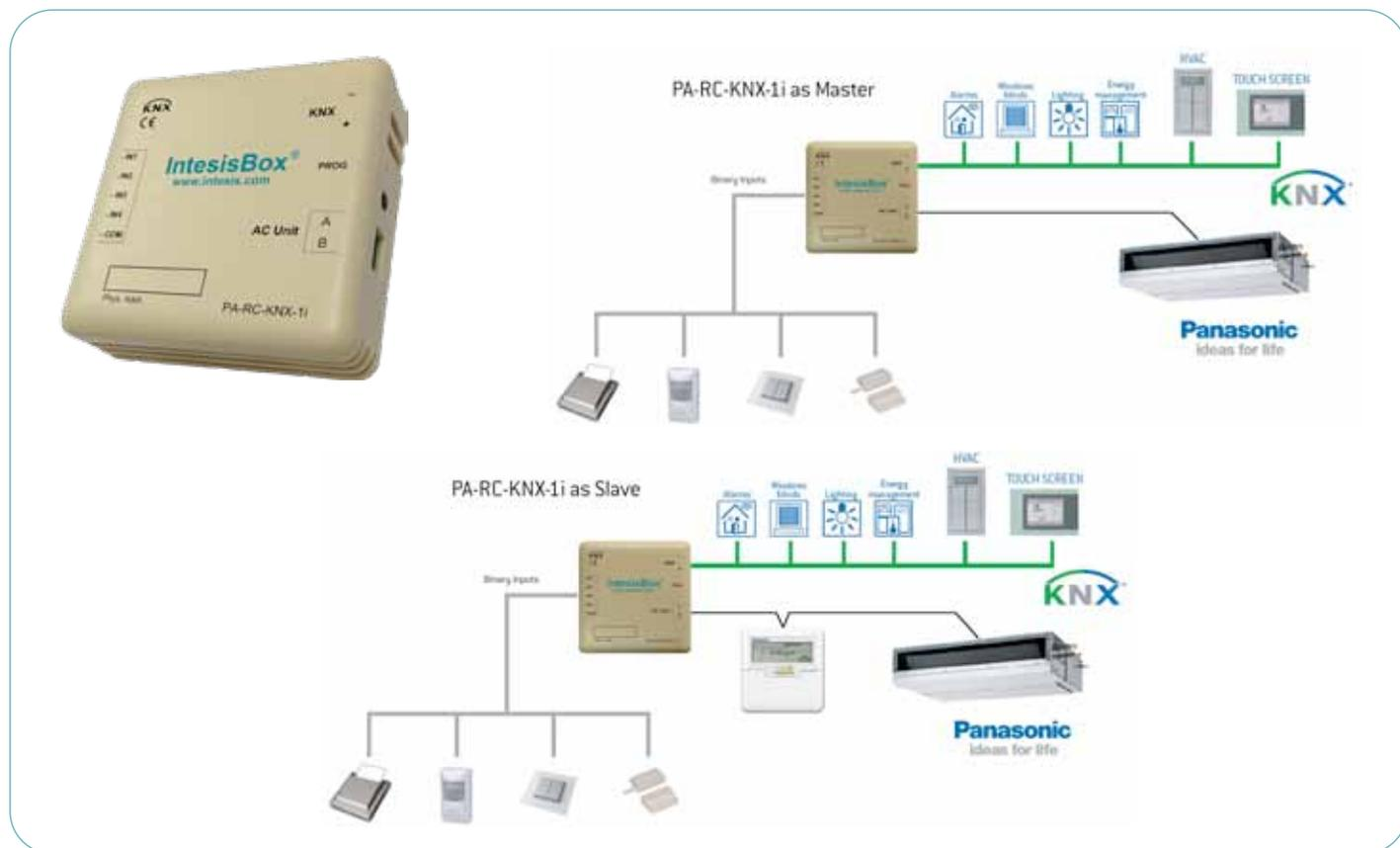

Specifications

- Bidirectional: Monitoring and Control
- Configuration from ETS
- Direct connection to KNX bus and to the AC indoor unit
- 4 binary inputs for potential-free contacts
- Connection type: 2 wires without polarity.
- Total maximum distance: 200 m.
- No external power supply required
- Small size (WxHxD): 71 x 71 x 27 mm

Main features

- Easy installation as Slave or Master in parallel with Panasonic remote controllers.
- Great integration flexibility. Configured directly from the ETS.
- Special communication objects for increasing comfort and energy savings: Open window, Working hours counter, Save /execute scenes, Enable/Disable device, Enable/disable remote controller,...
- Virtual temperature functionality. Useful when an external ambient temperature reference is required (KNX sensor or thermostat) or when the heating and AC unit need to be controlled from the same KNX thermostat.
- Simultaneous control from KNX and the Air Conditioner Remote Controller.

Info

Datasheet: http://www.intesis.com/pdf/IntesisBox_PA-RC-KNX-1i_datasheet_eng.pdf

Compatibility list: http://www.intesis.com/pdf/IntesisBox_PA-RC-xxx-1_AC_Compatibility.pdf

PA-RC2-KNX-1i

IntesisBox® PA-RC2-KNX-1i gateway allows Monitoring and bidirectional control of all the parameters and functionality of PANASONIC air conditioners from KNX installations. Compatible with FS and FSM Series manufactured by PANASONIC. 4 free-use binary inputs.

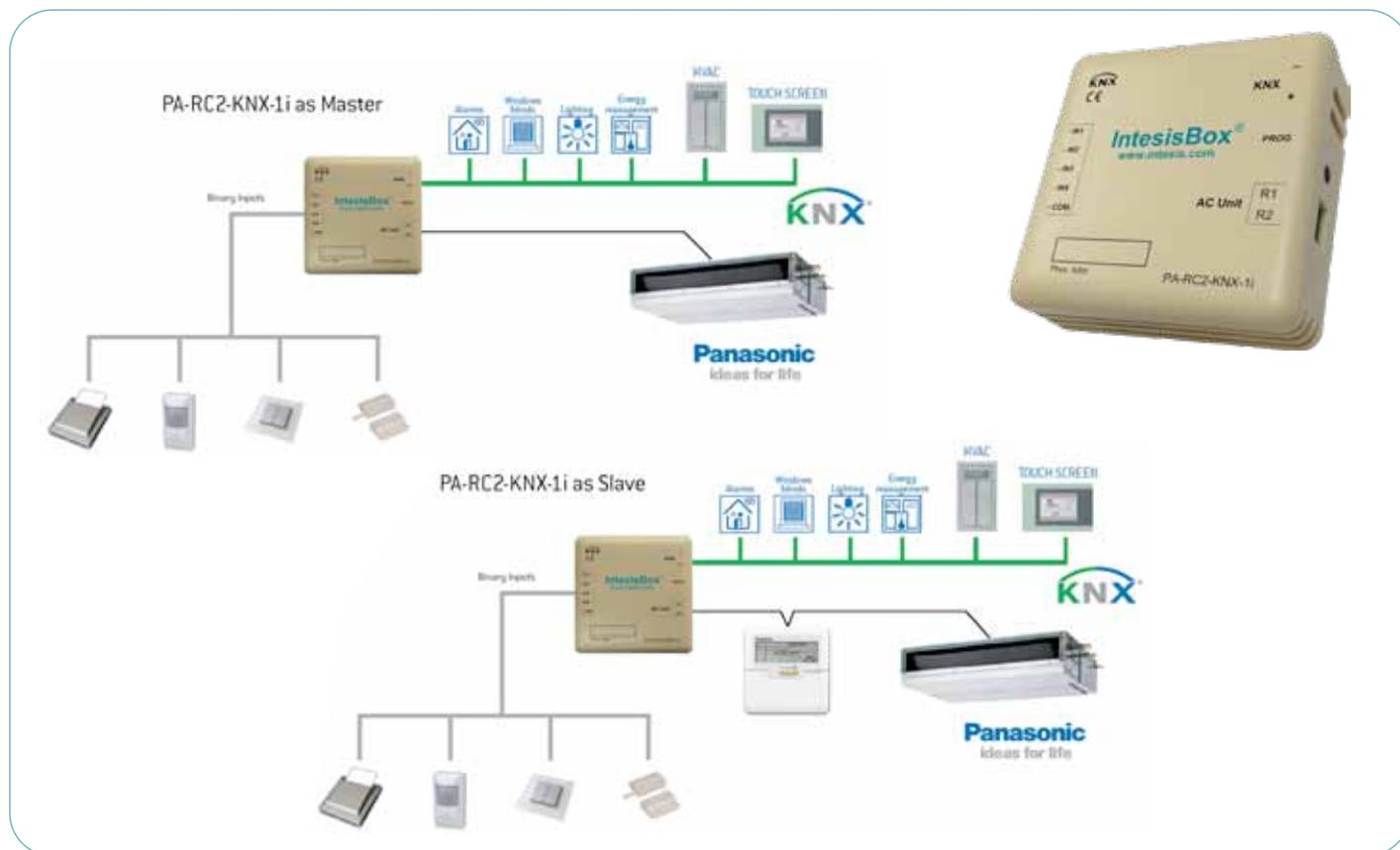

Specifications

- Bidirectional: Monitoring and Control
- Configuration from ETS
- Direct connection to KNX bus and to the AC indoor unit
- 4 binary inputs for potential-free contacts
- Connection type: 2 wires without polarity.
- Total maximum distance: 500 m.
- No external power supply required
- Small size (WxHxD): 71 x 71 x 27 mm

Main features

- Easy installation as Slave or Master in parallel with Panasonic remote controllers.
- Great integration flexibility. Configured directly from the ETS.
- Special communication objects for increasing comfort and energy savings: Open window, Working hours counter, Save /execute scenes, Enable/Disable device, Enable/disable remote controller,...
- Ambient temperature functionality. Useful when an external ambient temperature reference is required (KNX sensor or thermostat) or when the heating and AC unit need to be controlled from the same KNX thermostat.
- Simultaneous control from KNX and the Air Conditioner Remote Controller.

Info

Datasheet: http://www.intesis.com/pdf/IntesisBox_PA-RC2-KNX-1i_datasheet_eng.pdf

Compatibility: http://intesis.com/pdf/IntesisBox_PA-RC2-xxx-1_Panasonic_Compatibility.pdf

PA-AC-KNX-64/128

IntesisBox® PA-AC-KNX-64 / 128 gateways have been specially designed, in collaboration with Panasonic, to allow monitoring and bidirectional control of all the parameters and functionality of Panasonic air conditioning ECOi and PACi indoor units from KNX installations.

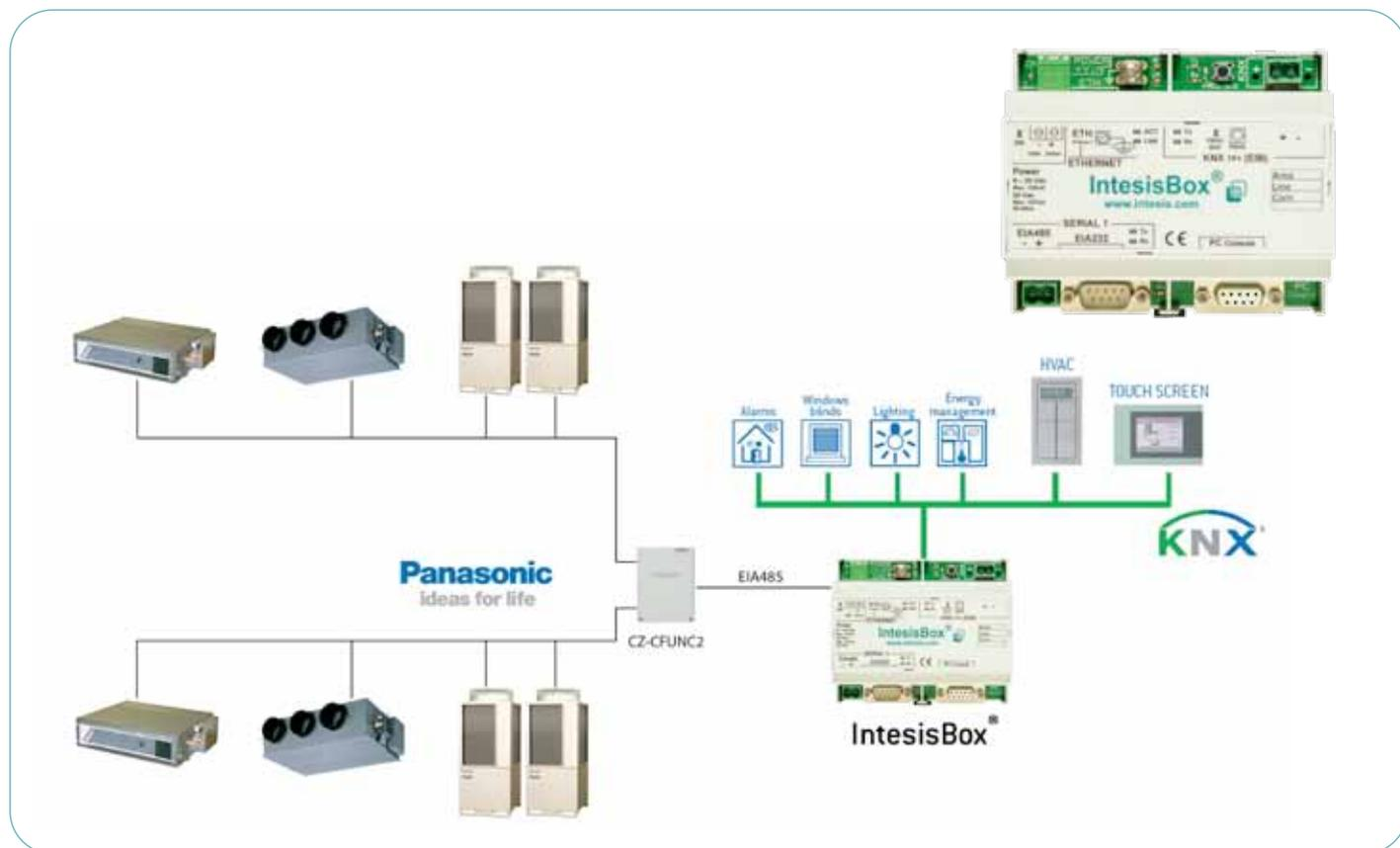

Specifications

- Bidirectional: Monitoring and Control
- Robust and reliable hardware
- Direct connection to KNX bus
- Independent management of communications
- Power supply: 9 to 24Vdc or 24Vac
- Standard DIN-Rail 6 modules enclosure

Models available

- PA-AC-KNX-64 (64 indoor units and 30 outdoor units)
- PA-AC-KNX-128 (128 indoor units and 30 outdoor units)

Info

Datasheet: http://www.intesis.com/pdf/IntesisBox_PA-AC-KNX-64-128_datasheet_eng.pdf

Main features

- Easy installation. Connection of PANASONIC communication interface CZ-CFUN2 to IntesisBox® through EIA485.
- Great integration flexibility. Using the supplied software LinkBoxEIB, a complete set of communication objects can be accessed.
- Simultaneous control from KNX and the Panasonic remote controller.

AK-AC-KNX-4 / AK-AC-KNX-8 AK-AC-KNX-16 / AK-AC-KNX-64

IntesisBox® AK-AC-KNX-4 / 8 / 16 / 64 gateways have been specially designed, in collaboration with Arçelik, to allow monitoring and bidirectional control of all the parameters and functionality of Arçelik air conditioners from KNX installations.

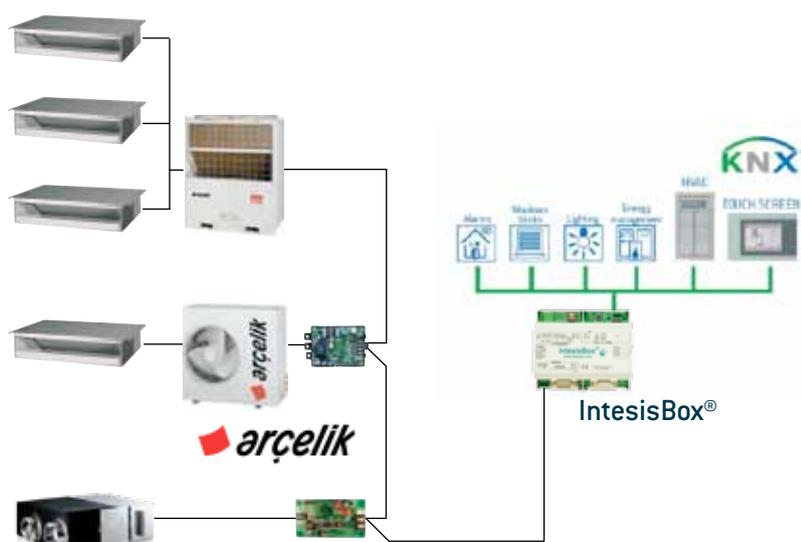

AK accessories

PMNFP14A1*



PHNFP14A0*



* Accessories PMNFP14A1 / PHNFP14A0 supplied by Arçelik.

Specifications

- Bidirectional: Monitoring and Control
- Robust and reliable hardware
- Direct connection to KNX bus
- Independent management of communications
- Power supply: 9 to 24Vdc or 24Vac
- Standard DIN-Rail 6 modules enclosure

Models available

- AK-AC-KNX-4 (Maximum 4 indoor units)
- AK-AC-KNX-8 (Maximum 8 indoor units)
- AK-AC-KNX-16 (Maximum 16 indoor units)
- AK-AC-KNX-64 (Maximum 64 indoor units)

Info

Datasheet: http://www.intesis.com/pdf/IntesisBox_AK-AC-KNX-16-64_datasheet_eng.pdf

Compatibility list: http://www.intesis.com/pdf/IntesisBox_AK-AC-xxx-MIU_AC_Compatibility.pdf

Main features

- Easy installation. Direct connection to all outdoor units (communication interface PMNFP14A1, when needed) and Heat recovering units (communication interface PHNFP14A0, when needed) through the RS485 Bus.
- Great integration flexibility. Using the supplied software LinkBoxEIB, a complete set of communication objects can be accessed.
- Simultaneous control from KNX and the Arçelik remote controller.

LG-AC-KNX-4 / LG-AC-KNX-8 LG-AC-KNX-16 / LG-AC-KNX-64

IntesisBox® LG-AC-KNX-4 / 8 / 16 / 64 gateways have been specially designed, in collaboration with LG, to allow monitoring and bidirectional control of all the parameters and functionality of LG air conditioners from KNX installations.

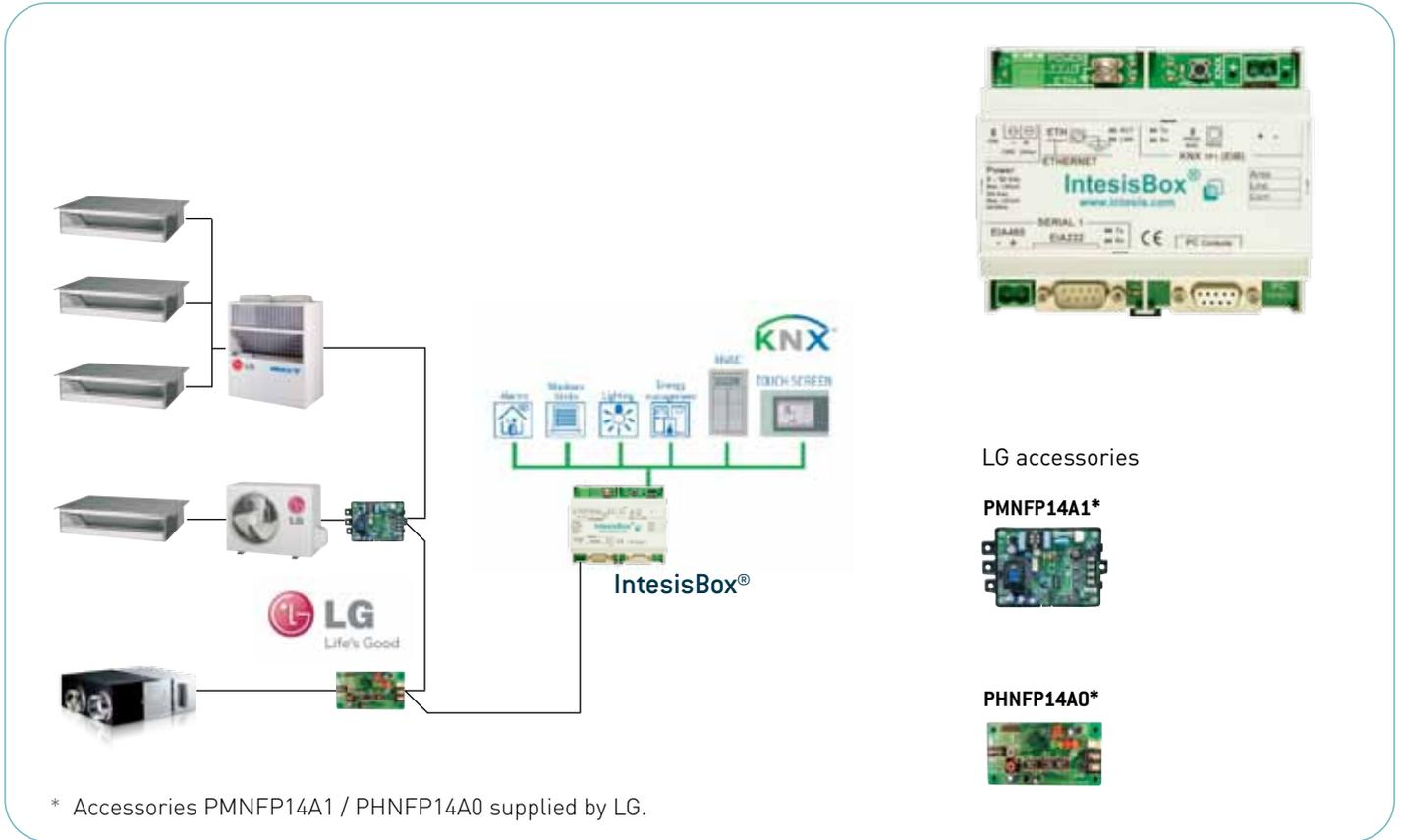

LG accessories

PMNFP14A1*



PHNFP14A0*



* Accessories PMNFP14A1 / PHNFP14A0 supplied by LG.

Specifications

- Bidirectional: Monitoring and Control
- Robust and reliable hardware
- Direct connection to KNX bus
- Independent management of communications
- Power supply: 9 to 24Vdc or 24Vac
- Standard DIN-Rail 6 modules enclosure

Models available

- LG-AC-KNX-4 (Maximum 4 indoor units)
- LG-AC-KNX-8 (Maximum 8 indoor units)
- LG-AC-KNX-16 (Maximum 16 indoor units)
- LG-AC-KNX-64 (Maximum 64 indoor units)

Info

Datasheet: http://www.intesis.com/pdf/IntesisBox_LG-AC-KNX-16-64_datasheet_eng.pdf

Compatibility list: http://www.intesis.com/pdf/IntesisBox_LG-AC-xxx-MIU_AC_Compatibility.pdf

Main features

- Easy installation. Direct connection to all outdoor units (communication interface PMNFP14A1, when needed) and Heat recovering units (communication interface PHNFP14A0, when needed) through the RS485 Bus.
- Great integration flexibility. Using the supplied software LinkBoxEIB, a complete set of communication objects can be accessed.
- Simultaneous control from KNX and the LG remote controller.

SM-AC-KNX-4 / SM-AC-KNX-8 / SM-AC-KNX-16 SM-AC-KNX-64 / SM-AC-KNX-128

IntesisBox® SM-AC-KNX-4 / 8 / 16 / 64 / 128 gateways have been specially designed, in collaboration with SAMSUNG, to allow monitoring and bidirectional control of all the parameters and functionality of SAMSUNG air conditioners from KNX installations.

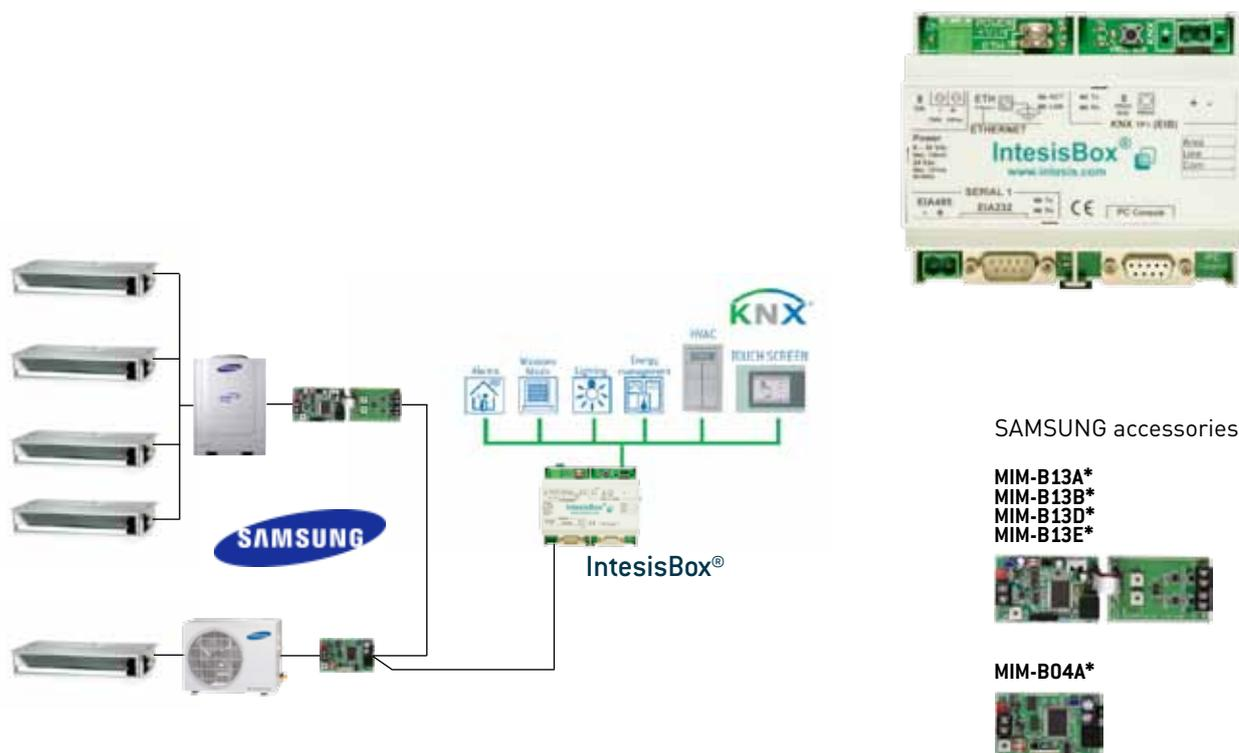

* Accessories MIM-B13A, MIM-B13B, MIM-B13D, MIM-B13E or MIM-B04A are supplied by SAMSUNG.

Specifications

- Bidirectional: Monitoring and Control
- Robust and reliable hardware
- Direct connection to KNX bus
- Independent management of communications
- Power supply: 9 to 24Vdc or 24Vac
- Standard DIN-Rail 6 modules enclosure

Models available

- SM-AC-KNX-4 (4 indoor units and 16 communication interfaces*)
- SM-AC-KNX-8 (8 indoor units and 16 communication interfaces*)
- SM-AC-KNX-16 (16 indoor units and communication interfaces*)
- SM-AC-KNX-64 (64 indoor units and 16 communication interfaces*)
- SM-AC-KNX-128 (128 indoor units and 16 communication interfaces*).

* MIM-B13A, MIM-B13B, MIM-B13D, MIM-B13E or MIM-B04A accessories supplied by Samsung

Info

Datasheet: http://www.intesis.com/pdf/IntesisBox_SM-AC-KNX-16-64-128_datasheet_eng.pdf

Compatibility list: http://www.intesis.com/pdf/IntesisBox_SM-AC-xxx-MIU_AC_Compatibility.pdf

Main features

- Easy installation. Connection of external unit to a SAMSUNG communication interfaces MIM-B13A, MIM-B13B, MIM-B13D MIM-B13E or MIM-B04A. Connection to IntesisBox® through RS485.
- Great integration flexibility. Using the supplied software LinkBoxEIB, a complete set of communication objects can be accessed.
- Simultaneous control from KNX and the Samsung remote controller.

IBOX-KNX-AIRZONE

IntesisBox® IBOX-KNX-AIRZONE gateway has been specially designed, in collaboration with AIRZONE, to allow monitoring and bidirectional control of all the parameters and functionality of AIRZONE zoning systems from KNX installations.

AIRZONE INNOBUS SYSTEM

Airzone InnoBUS SYSTEM is an integral Climate Control system by zones that manages both air conditioning systems as well as heating systems. It controls equipment such as air heat pump or also chillers and fan coils, so it can work in cold mode or in heat mode; also systems of heat radiation can be controlled, as for example radiation floors or wall heaters.

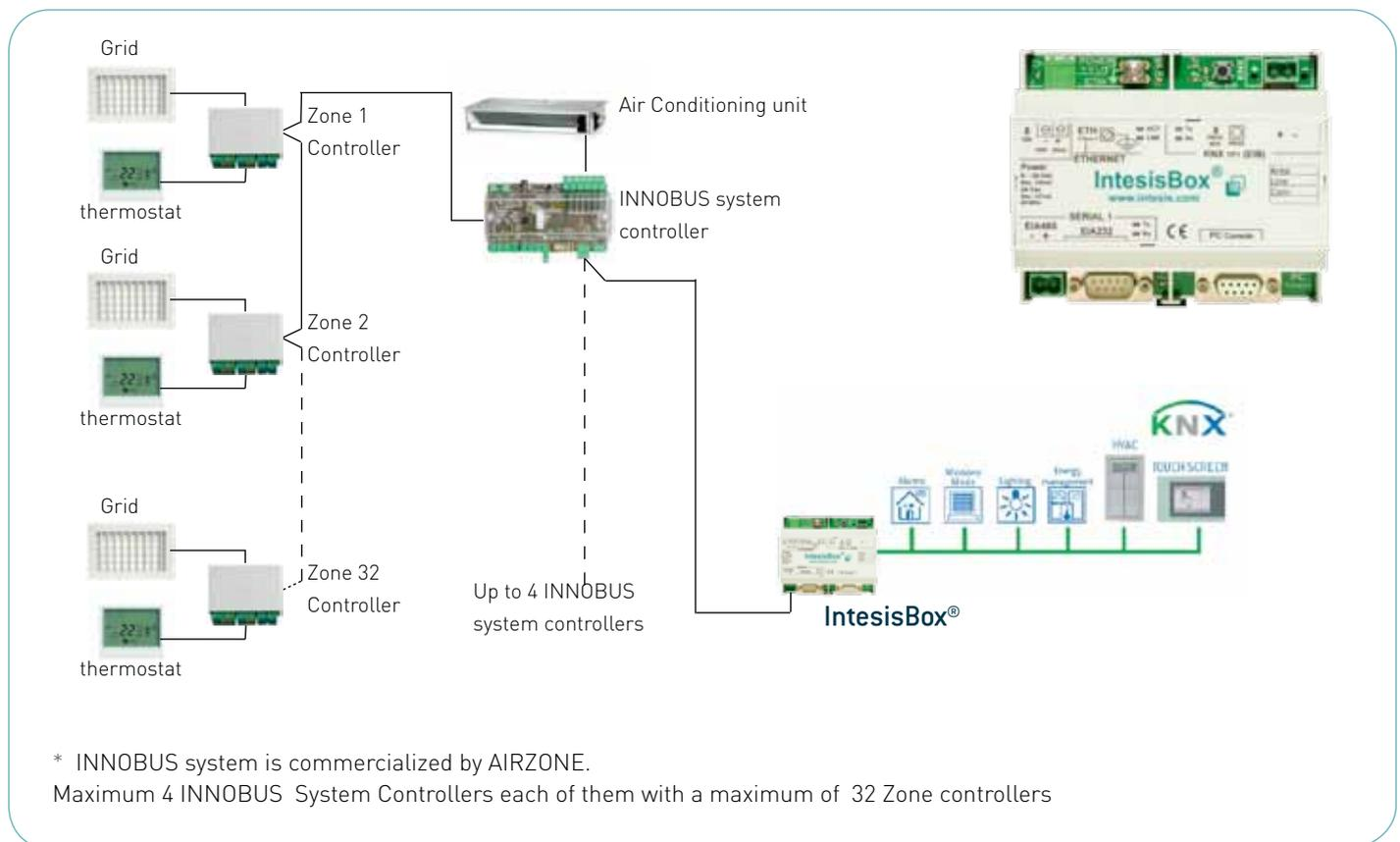

Specifications

- Bidirectional: Monitoring and Control
- Robust and reliable hardware
- Direct connection to KNX bus
- Independent management of communications
- Power supply: 9 to 24Vdc or 24Vac
- Standard DIN-Rail 6 modules enclosure

Main features

- Easy installation. Direct connection to all the INNOBUS system controllers (up to 4) through RS485 Bus.
- Great integration flexibility. Using the supplied software LinkBoxEIB, a complete set of communication objects can be accessed.
- Simultaneous control from KNX and the Airzone thermostats.

Info

Datasheet: http://www.intesis.com/pdf/IntesisBox_KNX_Airzone_datasheet_eng.pdf

IBOX-KNX-LON

IntesisBox® IBOX-KNX-LON gateway has been specially designed to allow monitoring and bidirectional control of all the parameters and functionality of systems and equipment with LonWorks® connectivity from KNX installations.

LonWorks® Devices

HVAC

- Air conditioners
- Coolers
- thermostats
- Fan-coil Controllers

Meters

- Electric meters
- Energy meters
- T² and Hr Probes

Automation

- B.M.S.
- PLC
- HMI

and many others



Integration example:

VRV DAIKIN Air conditioners equipped with LON gateway.

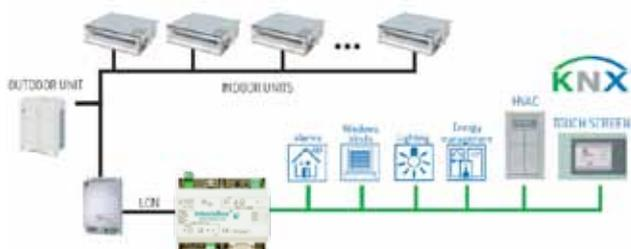

Integration example:

LON Fan-coil controllers.

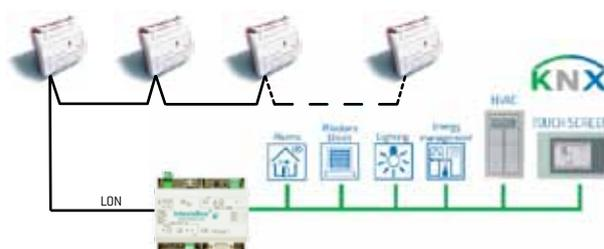

Specifications

- Bidirectional: Monitoring and Control
- Robust and reliable hardware
- Direct connection to KNX bus
- Independent management of communications
- Power supply: 9 to 24Vdc or 24Vac
- Standard DIN-Rail 6 modules enclosure

Models available

- IBOX-KNX-LON-100 (Maximum 100 control points and 128 LON devices)
- IBOX-KNX-LON-A (Maximum 500 control points and 128 LON devices)
- IBOX-KNX-LON-B (Maximum 4000 control points and 128 LON devices)

Info

Datasheet: http://www.intesis.com/pdf/IntesisBox_KNX_LON_datasheet_eng.pdf

Main features

- Easy installation. Direct connection to LonWorks devices through TP/FT-10 (2 wire) connection
- Great integration flexibility. Thanks to LinkBoxEIB supplied software. No bindings needed thanks to continuous polling readout. Access through physical address (Neuron-Id) or subnet node (commissioned devices) possible. LON expertise or commission tool not required.
- Advanced integration for centralized AC systems equipped with Lonworks interfaces, including meters, PLC's coolers, etc.

IBOX-KNX-MBRTU / IBOX-KNX-MBTCP

IntesisBox® IBOX-KNX-MBRTU / MBTCP gateways have been specially designed to allow monitoring and bidirectional control of all the parameters and functionality of systems and equipment with ModBus connectivity from KNX installations.

ModBus Devices

HVAC

- Air conditioners
- Coolers
- thermostats
- Fan-coil Controllers

Meters

- Electric meters
- Energy meters
- T° and Hr Probes

Automation

- B.M.S.
- PLC
- HMI

and many others

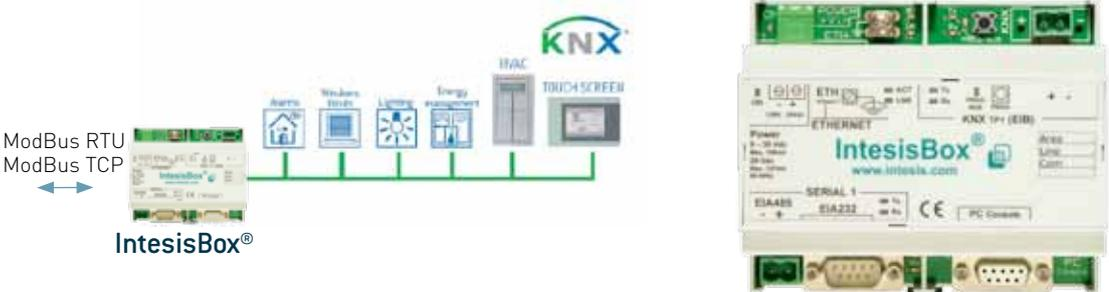

ModBus RTU
ModBus TCP

IntesisBox®

KNX TOUCH SCREEN

Integration example:
ModBus RTU chillers

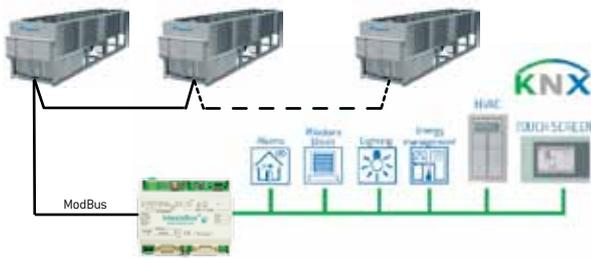

Integration example:
ModBus RTU electrical meters.

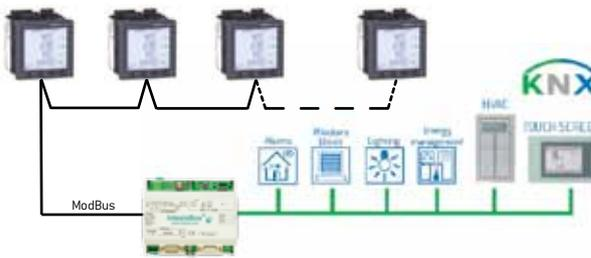

Specifications

- Bidirectional: Monitoring and Control
- Robust and reliable hardware
- Direct connection to KNX bus
- Independent management of communications
- Power supply: 9 to 24Vdc or 24Vac
- Standard DIN-Rail 6 modules enclosure

Models available

- IBOX-KNX-MBRTU-100 (100 control points and 254 ModBus RTU slave devices)
- IBOX-KNX-MBRTU-A / B (500 / 3000 control points and 254 ModBus RTU slave devices)
- IBOX-KNX-MBTCP-100 (100 control points and 5 ModBus TCP slave devices)
- IBOX-KNX-MBTCP-A / B (500 / 3000 control points and 5 ModBus TCP slave devices)

Info

Datasheet: http://www.intesis.com/pdf/IntesisBox_KNX_Modbus_RTU_master_datasheet_eng.pdf

Datasheet: http://www.intesis.com/pdf/IntesisBox_KNX_Modbus_TCP_master_datasheet_eng.pdf

Main features

- Easy installation. Direct connection to ModBus devices through RS485 [2 wire] or RS232 connection (IBOX-KNX-MBRTU) and Ethernet (IBOX-KNX-MBTCP).
- Great integration flexibility. The IntesisBox® ModBus Master interface reads continuously by polling the configured ModBus slave devices. Read values kept in IntesisBox® memory to be used when needed by the KNX system.
- Advanced integration of AC systems with ModBus interfaces from KNX like Ciatesa, Hitecsa, Lennox, Carrier, etc. and meters, PLC's coolers, etc.

IBOX-KNX-BAC

IntesisBox® IBOX-KNX-BAC gateway has been specially designed to allow monitoring and bidirectional control of all the parameters and functionality of systems and equipment with BACnet/IP connectivity from KNX installations.

BACnet devices

HVAC

- Air conditioners
- Coolers
- thermostats
- Fan-coil Controllers

Meters

- Electric meters
- Energy meters
- T° and Hr Probes

Automation

- B.M.S.
- PLC
- HMI

and many others



Integration example:

VRV DAIKIN Air conditioners equipped with BACnet gateway.

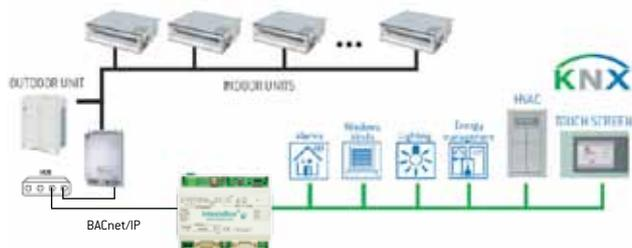

Integration example:

BACnet/IP Controllers.

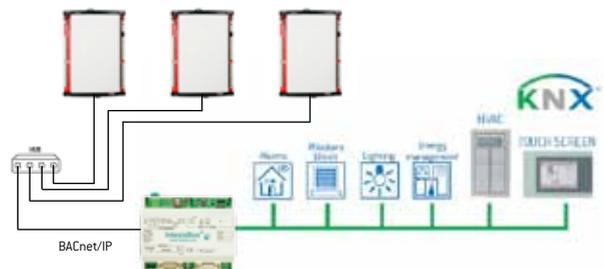

Specifications

- Bidirectional: Monitoring and Control
- Robust and reliable hardware
- Direct connection to KNX bus
- Independent management of communications
- Power supply: 9 to 24Vdc or 24Vac
- Standard DIN-Rail 6 modules enclosure

Models available

- IBOX-KNX-BAC-100 (Maximum 100 control points and 16 BACnet/IP devices)
- IBOX-KNX-BAC-A (Maximum 500 control points and 16 BACnet/IP devices)
- IBOX-KNX-BAC-B (Maximum 4000 control points and 16 BACnet/IP devices)

Info

Datasheet: http://www.intesis.com/pdf/IntesisBox_KNX_Bacnet_IP_Client_datasheet_eng.pdf

Main features

- Easy installation. Direct connection to the BACnet/IP network.
- Great integration flexibility. IntesisBox® IBOX-KNX-BAC is a BACnet/IP client that reads/writes points of other BACnet/IP devices. Read values kept in IntesisBox® memory to be used when needed by the KNX system.
- Advanced integration for centralized AC systems equipped with BACnet/IP interfaces, including meters, PLC's, HMI etc.

IBOX-KNX-DSC4020

IntesisBox® IBOX-KNX-DSC4020 has been specially designed to allow Monitoring and control of the DSC Maxsys PC4020 intrusion detection panel from KNX installations.

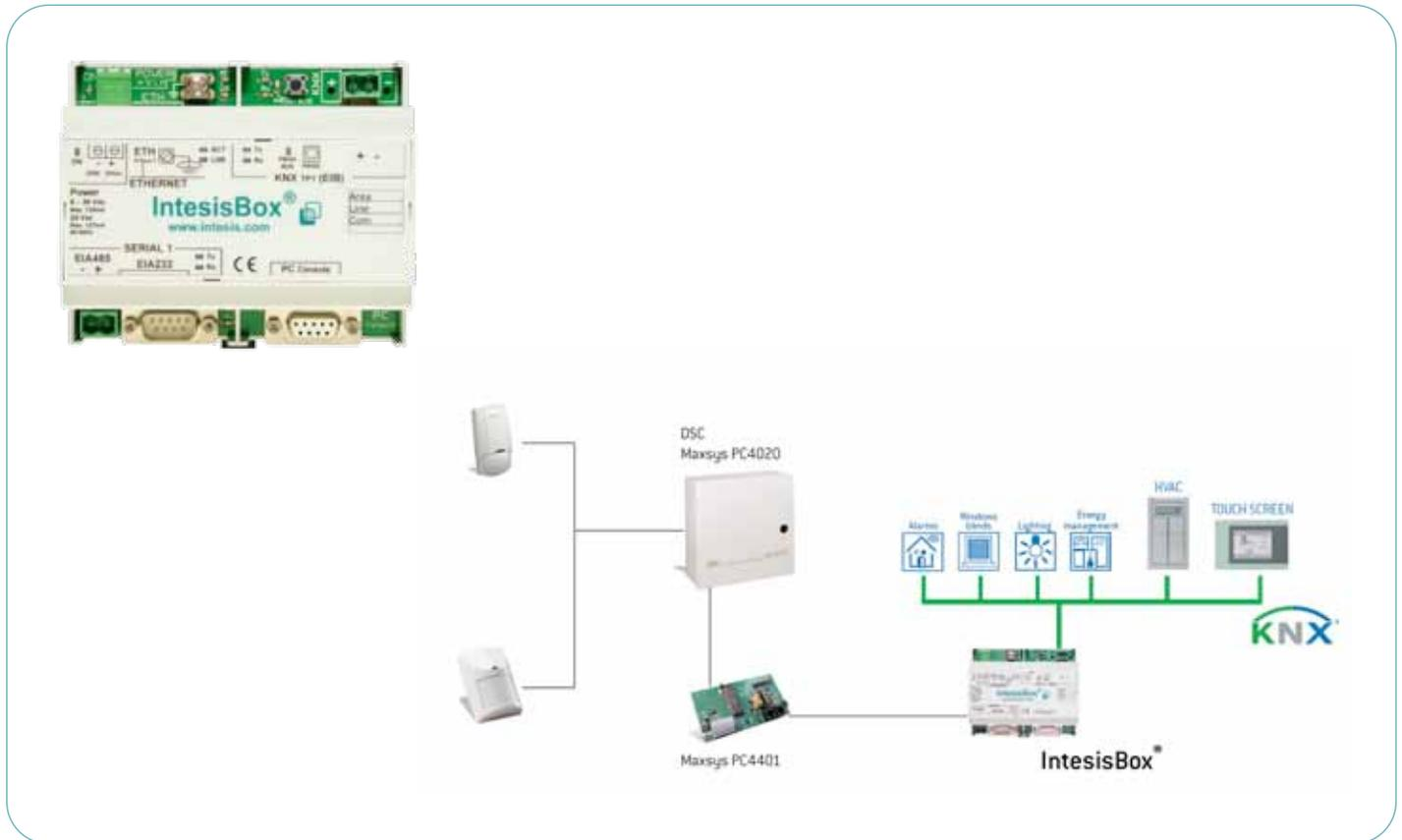

Specifications

- Bidirectional: Monitoring and Control
- Robust and reliable hardware
- Direct connection to KNX bus
- Independent management of communications
- Power supply: 9 to 24Vdc or 24Vac
- Standard DIN-Rail 6 modules enclosure

Models available

- IBOX-KNX-DSC4020 (up to 16 zones)

Info

Datasheet: http://www.intesis.com/pdf/IntesisBox_KNX_DSC-4020_datasheet_eng.pdf

Main features

- Easy installation. Direct connection to the MAXSYS Data Interface Module PC4401.
- Great integration flexibility. Possibility of arming/disarming zones, monitoring alarm status, communication errors, etc. Also possibility to monitor motion detectors status when disarmed.

IBOX-KNX-ENO-A1 / IBOX-KNX-ENO-A1C

IntesisBox® IBOX-KNX-ENO-A1 / A1C gateways have been specially designed to allow Monitoring and bidirectional control of all the parameters and functionality of EnOcean devices from KNX installations.

EnOcean Devices

Switches

- Wireless Switches
- Key card readers
- Window contacts
- Industrial switches

Sensors

- Temperature Sensors
- Humidity Sensors
- Movement Sensors
- Luminance Sensors

Automation

- Air Conditioners
- Actuators
- Room controllers and many others



Integration example:

Conventional EnOcean devices, Mitsubishi Electric and DAIKIN Air Conditioner using the EnOcean gateway.



Specifications

- Bidirectional: Monitoring and Control
- Configuration from ETS
- Direct connection to KNX bus
- No external power supply required
- Small size (WxHxD): 70 x 100 x 28 mm.

Models available

- IBOX-KNX-ENO-A1 (EnOcean freq. 868 Mhz Europe)
- IBOX-KNX-ENO-A1C (EnOcean freq. 315 MHz. USA and Asia)

** For other world locations contact your supplier.

Main features

- Easy installation. Direct connection to the KNX bus and installed within the EnOcean signal range.
- Great integration flexibility. The IntesisBox device sends/ receives telegrams from/to other EnOcean devices such as switches, card readers, thermostats, room controllers, actuators, etc.
- Advanced integration for IntesisBox AC EnOcean interfaces like Daikin and Mitsubishi Electric, Panasonic, Mitsubishi Heavy, ...

Info

Datasheet: http://www.intesis.com/pdf/IntesisBox_KNX_ENO_datasheet_eng.pdf



MODBUS



IntesisBox

products for Modbus systems



The **Modbus Organization** is a group of independent users and suppliers of automation devices that seeks to drive the adoption of the Modbus communication protocol suite and the evolution to address architectures for distributed automation systems across multiple market segments. The Modbus Organization will also provide the infrastructure to obtain and share information about the protocols, their application and certification to simplify implementation by users resulting in reduced costs. The Modbus Organization is a membership-based trade association, incorporated as "Modbus Organization, Inc." under the laws of the Commonwealth of Massachusetts, USA.

Modbus Protocol is a messaging structure developed by Modicon in 1979. It is used to establish master-slave/client-server communication between intelligent devices. It is a de facto standard, truly open and the most widely used network protocol in the industrial manufacturing environment. Modbus is used in multiple master-slave applications to monitor and program devices; to communicate between intelligent devices and sensors and instruments; to monitor field devices using PCs and HMIs. Modbus is also an ideal protocol for RTU applications where wireless communication is required. For this reason, it is used in innumerable gas and oil and substation applications. But Modbus is not only an industrial protocol. Building, infrastructure, transportation and energy applications also make use of its benefits.

For further information, please visit www.modbus.org

IntesisBox® Modbus AC gateways

Specially designed, in collaboration with several manufacturers like Mitsubishi Electric, Daikin, Samsung, Fujitsu to allow supervision and bidirectional control of all the parameters and functionality of Air conditioners from MODBUS installations.

- Easy installation. Direct connection to RS-485 or Ethernet and the AC indoor unit
- Great integration flexibility, with supervision and control of MODBUS registers allowing an easy and fast integration with the basic parameters, and a complete supervision and control for all the AC unit functionality
- Advanced integration with air conditioner: a complete bidirectional communication and simultaneous control from Modbus and the infrared Air Conditioner remote controller.

IntesisBox Modbus interfaces for other protocols

IntesisBox® IBOX-MBS-XXX gateways have been specially designed to allow supervision and bidirectional control of all the parameters and functionality of systems and equipment with KNX, MBUS, BACNet/IP, BACNet MSTP, LonWorks, and DALI installations and Atersa or Fidelio systems from Modbus installations.

- Great integration flexibility
- Advanced integration with any SCADA such as Wanderware, Intellution, ABB, Schneider ... as well as energy and gas meters, PLC's, coolers, fan-coil controllers, fire panels, security panels, etc.

MODBUS

ME-AC-MBS-1 / ME-AC-MBS1-2110

IntesisBox® ME-AC-MBS-1 and ME-AC-MBS-1-2110 gateways have been specially designed, in collaboration with Mitsubishi Electric, to allow monitoring and bidirectional control of all the parameters and functionality of Mitsubishi Electric Mr. Slim and Domestic air conditioning Series from ModBus installations.



ME-AC-MBS-1



ME-AC-MBS-1-2110*

- Wonderware
- Intellution
- ABB
- and many others

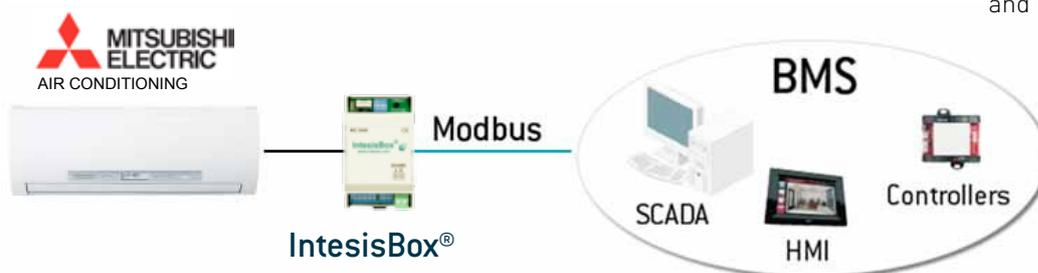

Specifications

- Bidirectional: Monitoring and Control
- Fast and easy installation
- 2 digital inputs and 1 digital output, mapped in 3 independent ModBus registers
- Direct connection to RS-485 bus and the AC indoor unit
- No external power supply required
- Small size (WxHxD): 93 x 53 x 58 mm

Main features

- Easy installation inside the air conditioning indoor unit. Cable for CN105 or CN92 connector supplied.
- Great integration flexibility. Easy integration with basic parameters up to complete monitoring of the AC unit operation is possible.
- Configuration from both on-board DIP-switches and MODBUS registers.
- Special communication objects for increasing comfort and energy savings: Open window, Working hours counter, Save /execute scenes, Enable/Disable device, Enable/disable remote controller,...
- Simultaneous control from ModBus and the Mitsubishi Electric Remote controller.

Info

Datasheet: http://www.intesis.com/pdf/IntesisBox_ME-AC-MBS-1_datasheet_eng.pdf

Datasheet: http://www.intesis.com/pdf/IntesisBox_ME-AC-MBS-1-2110_datasheet_eng.pdf

Compatibility list: http://www.intesis.com/pdf/IntesisBox_ME-AC-xxx-1_AC_Compatibility.pdf

ME-AC-MBS-50 / ME-AC-MBS-100

IntesisBox® ME-AC-MBS-50 / 100 gateways have been specially designed, in collaboration with Mitsubishi Electric, to allow monitoring and bidirectional control of all the parameters and functionality of Mitsubishi Electric air conditioners using G-50A, GB-50A or AG-150A controllers from ModBus installations.

Compatible with all Mitsubishi Electric Air Conditioning units connected to centralized controls

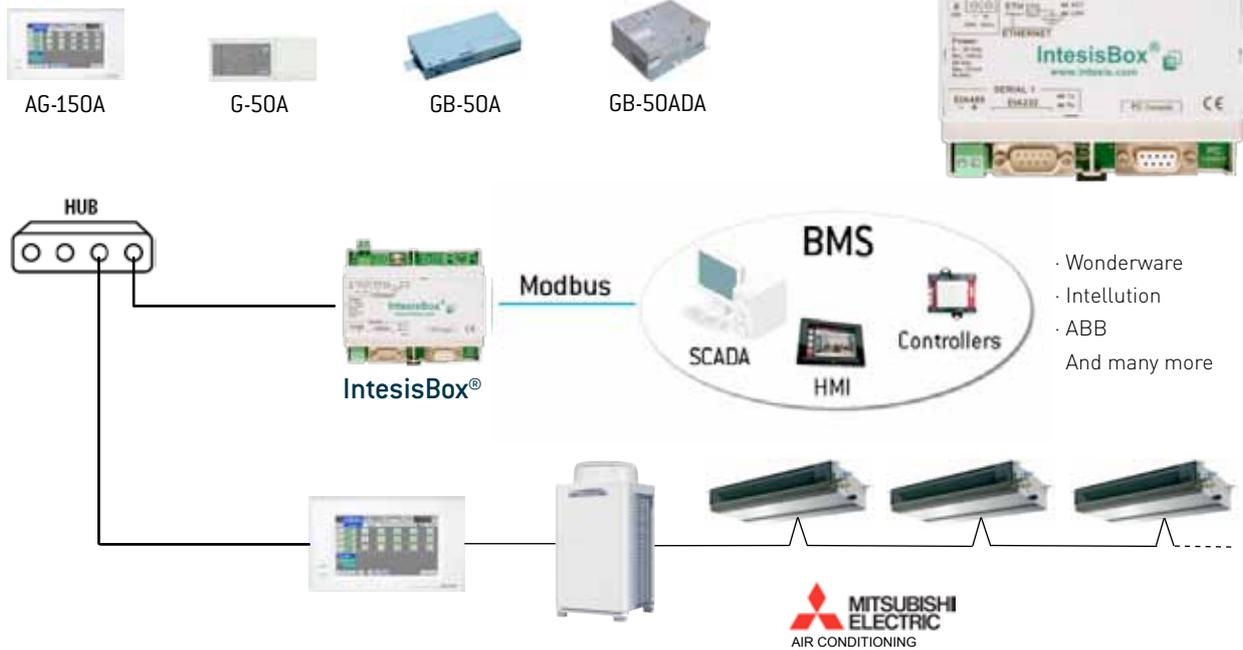

* The AG-150A must have the FGWEBASIC function (Web basic package). Ask Mitsubishi Electric.

Specifications

- Bidirectional: Monitoring and Control
- Robust and reliable hardware
- ModBus TCP or ModBus RTU RS-485/RS-232
- Independent management of communications
- Power supply: 9 to 24Vdc or 24Vac
- Standard DIN-Rail 6 modules enclosure

Models available

- ME-AC-MBS-50: supports up to 1 G50 and 50 City Multi groups.
- ME-AC-MBS-100: supports up to 2 G50s and 100 City Multi groups.

Info

Datasheet : http://www.intesis.com/pdf/IntesisBox_Modbus_Server_ME_G50_datasheet_eng.pdf

Main features

- Compatible with all Mitsubishi Electric Air Conditioning units connected to centralized controls G-50A / GB-50A / AG-150A / GB-50ADA.
- Easy installation. To be connected through Ethernet to the centralized controls
- Great integration flexibility. Using the software LinkBoxMB, ModBus registers can be accessed. Easy integration with basic parameters up to complete monitoring of the AC unit operation is possible. LinkBoxMB supplied without charge.
- Advanced integration with air conditioner. Simultaneous control from ModBus and the Mitsubishi Electric Remote controller.

MH-RC-MBS-1

IntesisBox® MH-RC-MBS-1 gateway allows monitoring and bidirectional control of all the parameters and functionality of Mitsubishi Heavy Industries air conditioners from Modbus installations. Compatible with all the models of the FD, KX6 and KXR6 Series manufactured by Mitsubishi Heavy Industries.



Specifications

- Bidirectional: Monitoring and Control
- Fast and easy installation
- Direct connection to RS-485 bus and the AC indoor unit
- Configuration from both on-board DIP-switches and MODBUS registers.
- No external power supply required
- Small size (WxHxD): 93 x 53 x 58 mm

Main features

- Easy installation as Slave or Master in parallel with MHI remote controllers.
- Great integration flexibility. Monitoring and control from basic parameters to a complete Monitoring and control of the AC units is possible.
- Special communication objects for increasing comfort and energy savings: Open window, Working hours counter, Save /execute scenes, Enable/Disable device, Enable/disable remote controller,...
- Simultaneous control from ModBus and the MHI Remote controller.

Info

Datasheet: http://www.intesis.com/pdf/IntesisBox_MH-RC-MBS-1_datasheet_eng.pdf

Compatibility list: http://www.intesis.com/pdf/IntesisBox_MH-RC-xxx-1_AC_Compatibility.pdf

MH-AC-MBS-48 / MH-AC-MBS-128

IntesisBox® MH-AC-MBS-48 / 128 gateways have been specially designed, in collaboration with Mitsubishi Heavy Industries, to allow monitoring and bidirectional control of all the parameters and functionality of Mitsubishi Heavy Industries air conditioning VRF Superlink I&II systems from ModBus installations.



Specifications

- Bidirectional: Monitoring and Control
- Robust and reliable hardware
- ModBus TCP or ModBus RTU RS-485/RS-232
- Independent management of communications
- Power supply: 230 VAC
- Size (WxHxD): 215 x 170 x 65 mm

Models available

- MH-AC-MBS-48: supports up to 48 indoor units
- MH-AC-MBS-128: supports up to 128 indoor units

Info

Datasheet: http://www.intesis.com/pdf/IntesisBox_MH-AC-MBS-48-128_datasheet_eng.pdf

Compatibility list: http://www.intesis.com/pdf/IntesisBox_MH-AC-xxx-1_AC_Compatibility.pdf

Main features

- Compatible with all Mitsubishi Heavy Industries units connected to SuperLink Bus.
- Easy installation. Direct connection to SuperLink Bus.
- Great integration flexibility. Using the software LinkBoxMB, ModBus registers can be accessed. Easy integration with basic parameters up to complete monitoring of the AC unit operation is possible.
- Advanced integration with air conditioner. Simultaneous control from ModBus and the Mitsubishi Heavy Industries Remote controller.

DK-AC-MBS-1

The DK-AC-MBS-1 interface allows a complete and natural integration of Daikin air conditioners into ModBus RTU (RS-485) networks. Compatible with Domestic Series manufactured by DAIKIN.

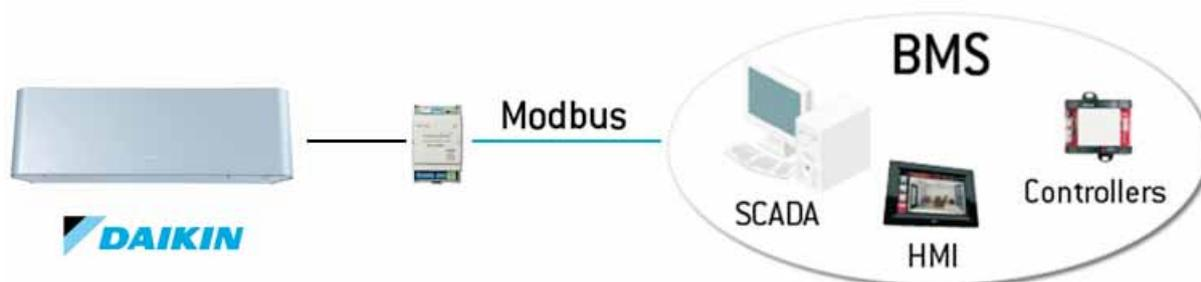

Specifications

- Bidirectional: Monitoring and Control
- Fast and easy installation
- Direct connection to RS-485 bus and the AC indoor unit
- Configuration from both on-board DIP-switches and MODBUS RTU.
- No external power supply required
- Small size (WxHxD): 93 x 53 x 58 mm

Main features

- Easy installation. Cable for S21 connector supplied.
- Great integration flexibility.
- Special communication objects for increasing comfort and energy savings: Open window, Working hours counter, Save /execute scenes, Enable/Disable device, Enable/disable remote controller,...
- Simultaneous control from ModBus and the Daikin Remote controller.

Info

Datasheet: http://www.intesis.com/pdf/IntesisBox_DK-AC-MBS-1_datasheet_eng.pdf

Compatibility list: http://www.intesis.com/pdf/IntesisBox_DK-AC-xxx-1_AC_Compatibility.pdf

DK-RC-MBS-1

IntesisBox® DK-RC-KNX-1 gateway allows monitoring and bidirectional control of all the parameters and functionality of DAIKIN Air conditioners from ModBus installations.
Compatible with SKY & VRV Series manufactured by DAIKIN.

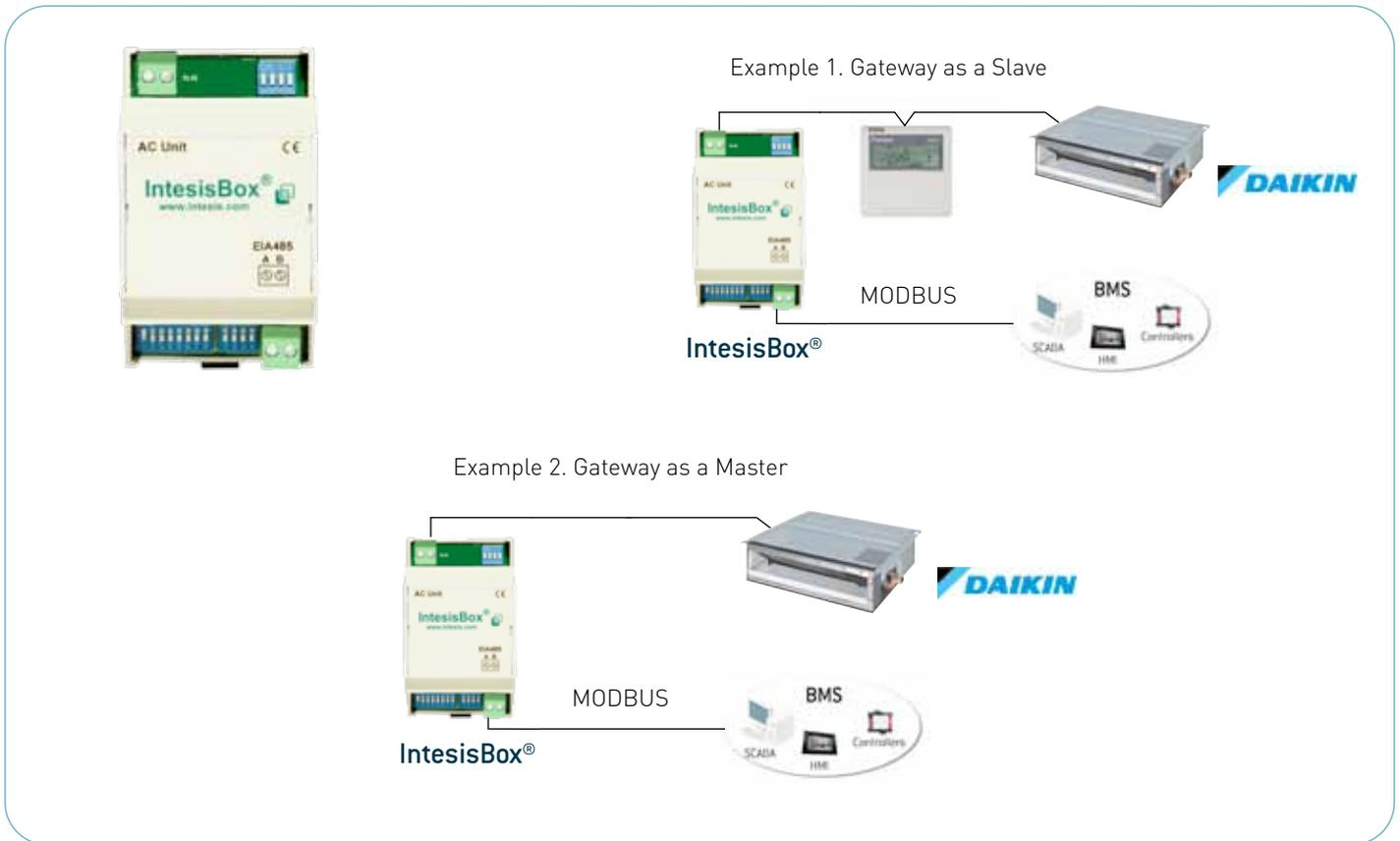

Specifications

- Bidirectional: Monitoring and Control
- Fast and easy installation
- Direct connection to RS-485 bus and the AC indoor unit
- Configuration from both on-board DIP-switches and MODBUS registers.
- No external power supply required
- Small size (WxHxD): 71 x 71 x 27 mm

Main features

- Easy installation as Slave or Master in parallel with Daikin remote controllers.
- Great integration flexibility. Easy integration with basic parameters up to complete monitoring and control of the AC unit operation is possible.
- Special communication objects for increasing comfort and energy savings: Open window, Working hours counter, Save /execute scenes, Enable/Disable device, Enable/disable remote controller,...
- Simultaneous control from ModBus and the Daikin Remote controller.

Info

Datasheet: http://www.intesis.com/pdf/IntesisBox_DK-RC-MBS-1_datasheet_eng.pdf

Compatibility list available at http://www.intesis.com/pdf/IntesisBox_DK-RC-xxx-1_AC_Compatibility.pdf

SM-AC-MBS-4 / SM-AC-MBS-8 / SM-AC-MBS-32 / SM-AC-MBS-64 / SM-AC-MBS-128

IntesisBox® SM-AC-KNX-4 / 8 / 32 / 64 / 128 gateways have been specially designed, in collaboration with SAMSUNG, to allow monitoring and bidirectional control of all the parameters and functionality of SAMSUNG Air Conditioners from ModBus installations.

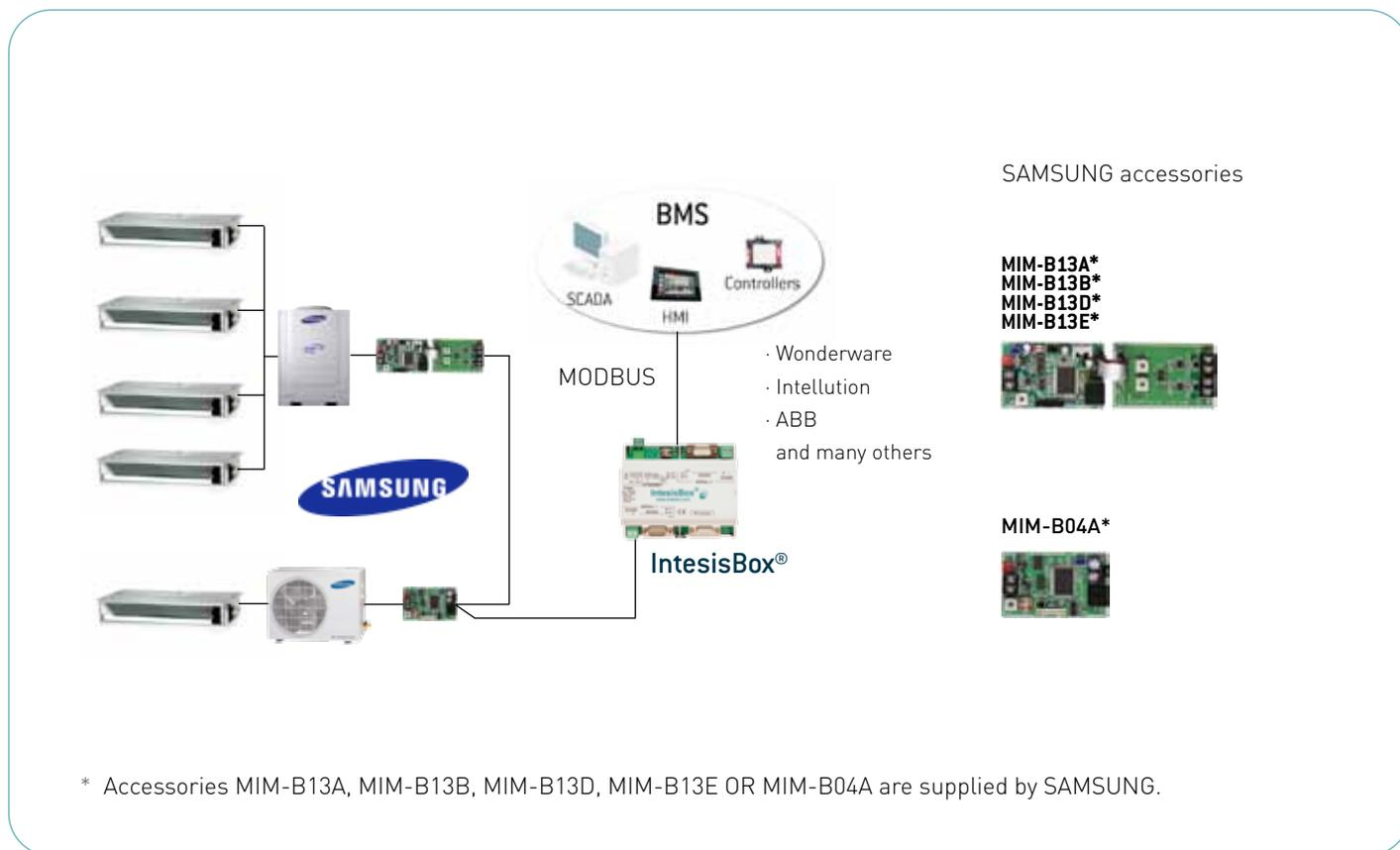

* Accessories MIM-B13A, MIM-B13B, MIM-B13D, MIM-B13E OR MIM-B04A are supplied by SAMSUNG.

Specifications

- Bidirectional: Monitoring and Control
- Robust and reliable hardware
- ModBus TCP or ModBus RTU RS-485/RS-232
- Independent management of communications
- Power supply: 9 to 24Vdc or 24Vac
- Standard DIN-Rail 6 modules enclosure

Models available

- SM-AC-MBS-4 (4 indoor units and 16 communication interfaces*)
- SM-AC-MBS-8 (8 indoor units and 16 communication interfaces*)
- SM-AC-MBS-32 (32 indoor units and 16 communication interfaces*)
- SM-AC-MBS-64 (64 indoor units and 16 communication interfaces*)
- SM-AC-MBS-128 (128 indoor units and 16 communication interfaces*)

* MIM-B13A, MIM-B13B, MIM-B13D, MIM-B13E or MIM-B04A accessories supplied by Samsung

Info

Datasheet: http://www.intesis.com/pdf/IntesisBox_SM-AC-MBS-32-64-128_datasheet_eng.pdf

Compatibility list: http://www.intesis.com/pdf/IntesisBox_SM-AC-xxx-MIU_AC_Compatibility.pdf

Main features

- Easy installation. Connection of SAMSUNG communication interfaces MIM-B13A, MIM-B13B, MIM-B13D, MIM-B13E or MIM-B04A to IntesisBox® through RS485.
- Great integration flexibility. Using the software LinkBoxMB, ModBus registers can be accessed. Easy integration with basic parameters up to complete monitoring of the AC unit operation is possible.
- Simultaneous control from ModBus and the Samsung Remote controller.

FJ-RC-MBS-1

IntesisBox® FJ-RC-MBS-1 allows monitoring and bidirectional control of all the functionality parameters of the Commercial and VRF Series of air conditioning units manufactured by Fujitsu and General, from any ModBus installation.

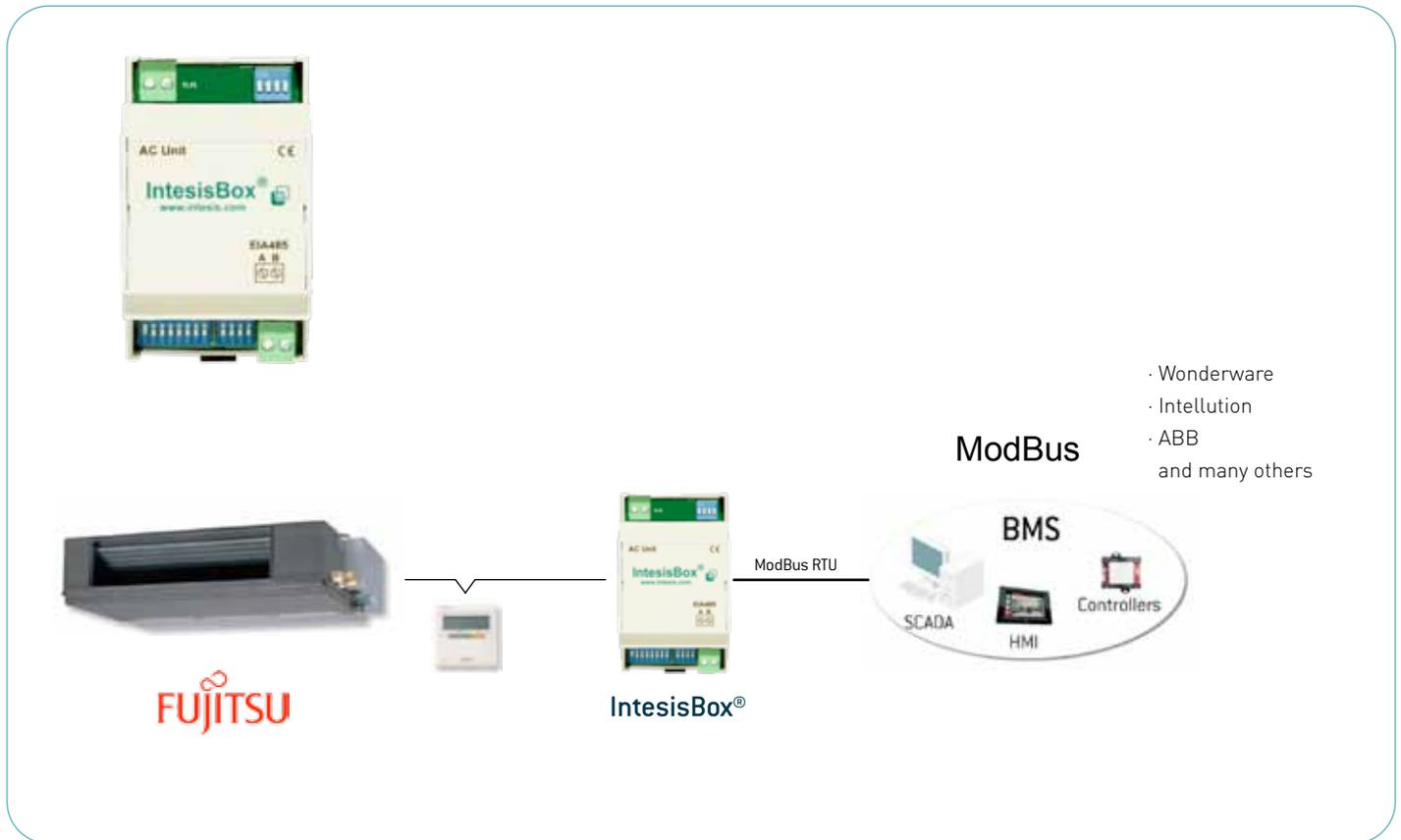

Specifications

- Bidirectional: Monitoring and Control
- Fast and easy installation
- Direct connection to RS-485 bus and the indoor unit
- No external power supply required
- Small size (WxHxD): 93 x 53 x 58 mm

Main features

- Easy installation connecting the gateway in parallel with the Fujitsu wired remote controller unit.
- Great integration flexibility. ModBus registers can be accessed. Easy integration with basic parameters up to complete monitoring of the AC unit operation is possible.
- Special communication objects for increasing comfort and energy savings: Open window, Working hours counter, Save /execute scenes, Enable/Disable device, Enable/disable remote controller,...
- Simultaneous control from ModBus and the Fujitsu Remote controller.

Info

Datasheet: http://www.intesis.com/pdf/IntesisBox_FJ-RC-MBS-1_datasheet_eng.pdf

Compatibility list: http://www.intesis.com/pdf/IntesisBox_FJ-RC-xxx-1_AC_Compatibility.pdf

PA-RC2-MBS-1

IntesisBox® PA-RC2-MBS-1 gateway allows Monitoring and bidirectional control of all the parameters and functionality of PANASONIC air conditioners from Modbus installations. Compatible with FS and FSM Series manufactured by PANASONIC.

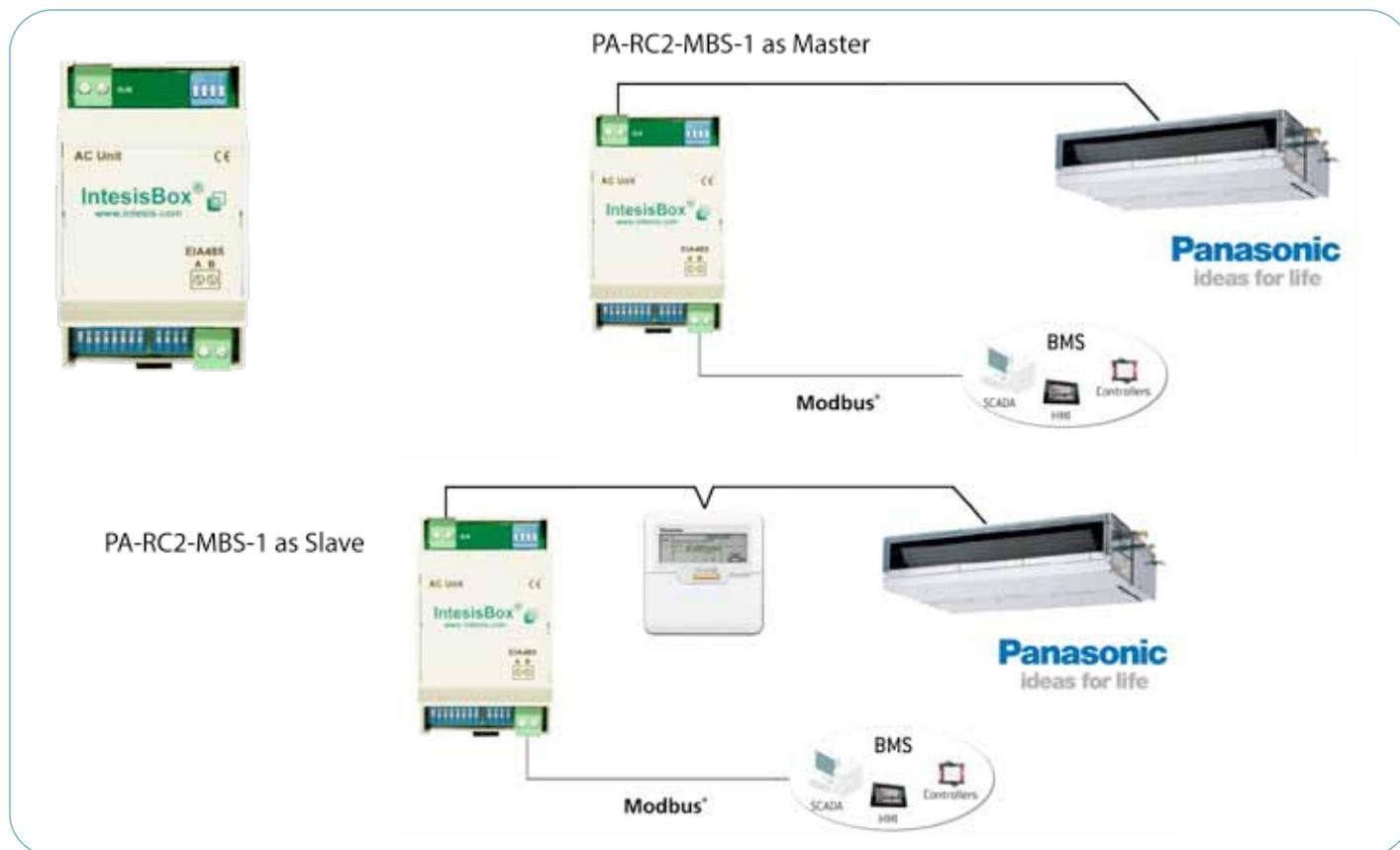

Specifications

- Bidirectional: Monitoring and Control
- Fast and easy installation
- Direct connection to RS-485 bus and the AC indoor unit
- Configuration from both on-board DIP-switches and MODBUS registers.
- No external power supply required
- Small size (WxHxD): 93 x 53 x 58 mm

Main features

- Easy installation as Slave or Master in parallel with Panasonic remote controllers.
- Great integration flexibility. Easy integration with basic parameters to a complete monitoring and control of the AC units is possible.
- Special communication objects for increasing comfort and energy savings: Open window, Working hours counter, Save /execute scenes, Enable/Disable device, Enable/disable remote controller,...
- Simultaneous control from ModBus and the Panasonic Remote controller.

Info

Datasheet: http://www.intesis.com/pdf/IntesisBox_PA-RC2-MBS-1_datasheet_eng.pdf

Compatibility: http://intesis.com/pdf/IntesisBox_PA-RC2-xxx-1_Panasonic_Compatibility.pdf

PA-AW-MBS-1

IntesisBox® PA-AW-MBS-1 gateway allows monitoring and bidirectional control of all the parameters and functionality of PANASONIC Aquarea air to water units from Modbus installations.

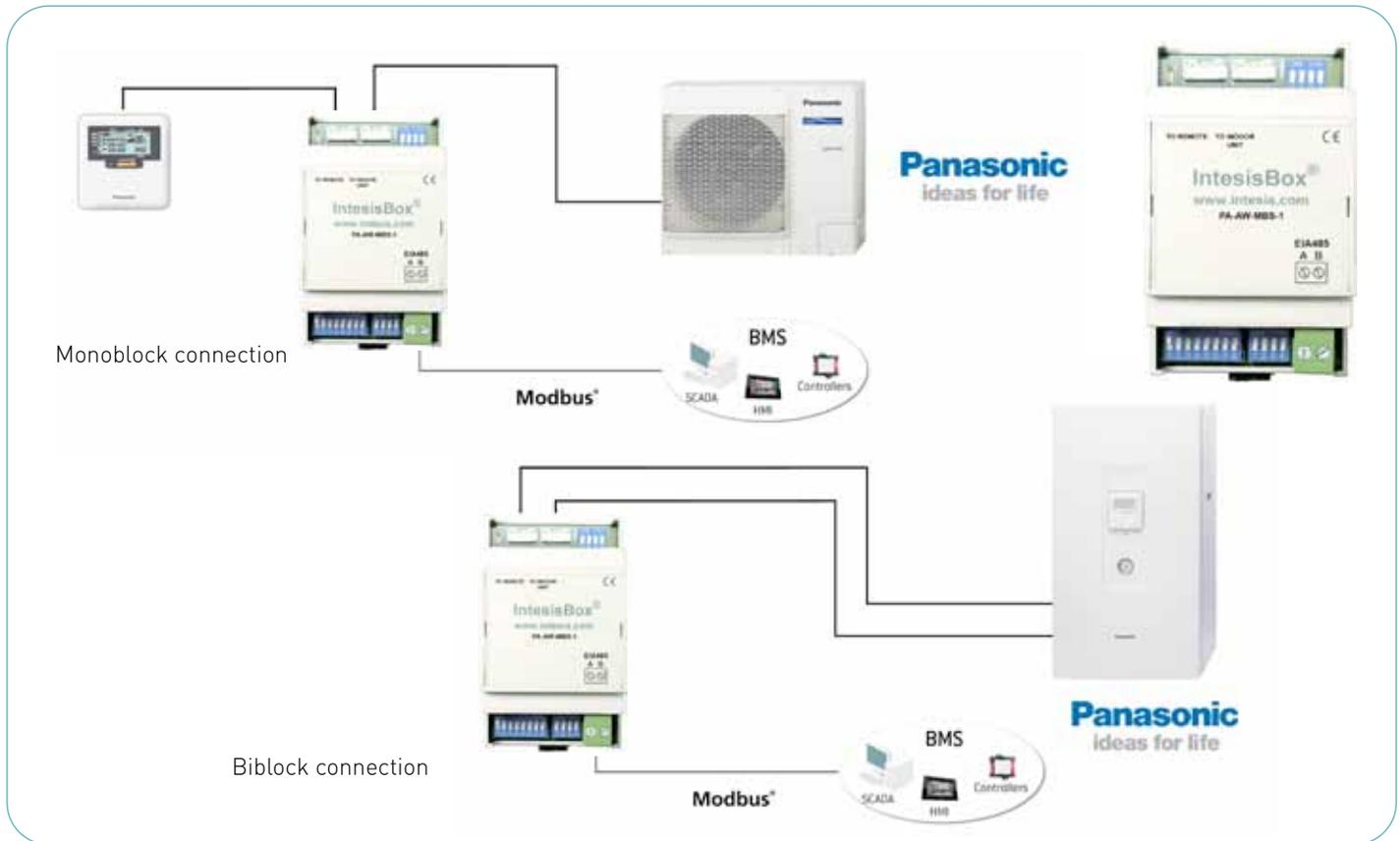

Specifications

- Bidirectional: Monitoring and Control
- Fast and easy installation
- Direct connection to RS-485 bus and the Aquarea unit
- Configuration from both on-board DIP-switches and MODBUS registers.
- No external power supply required
- Small size (WxHxD): 93 x 53 x 58 mm

Main features

- Easy installation as Slave or Master in parallel with Panasonic remote controllers.
- Great integration flexibility. Easy integration with basic parameters to a complete monitoring and control of the AC units is possible.
- Special registers for maintenance and functionality check purposes.
- Simultaneous control from ModBus and the Panasonic Remote controller.

Info

Datasheet: http://www.intesis.com/pdf/IntesisBox_PA-AW-MBS-1_datasheet_eng.pdf

IBOX-MBS-KNX

IntesisBox® IBOX-MBS-KNX gateway has been specially designed to allow monitoring and bidirectional control of all the parameters and functionality of KNX systems from ModBus installations.

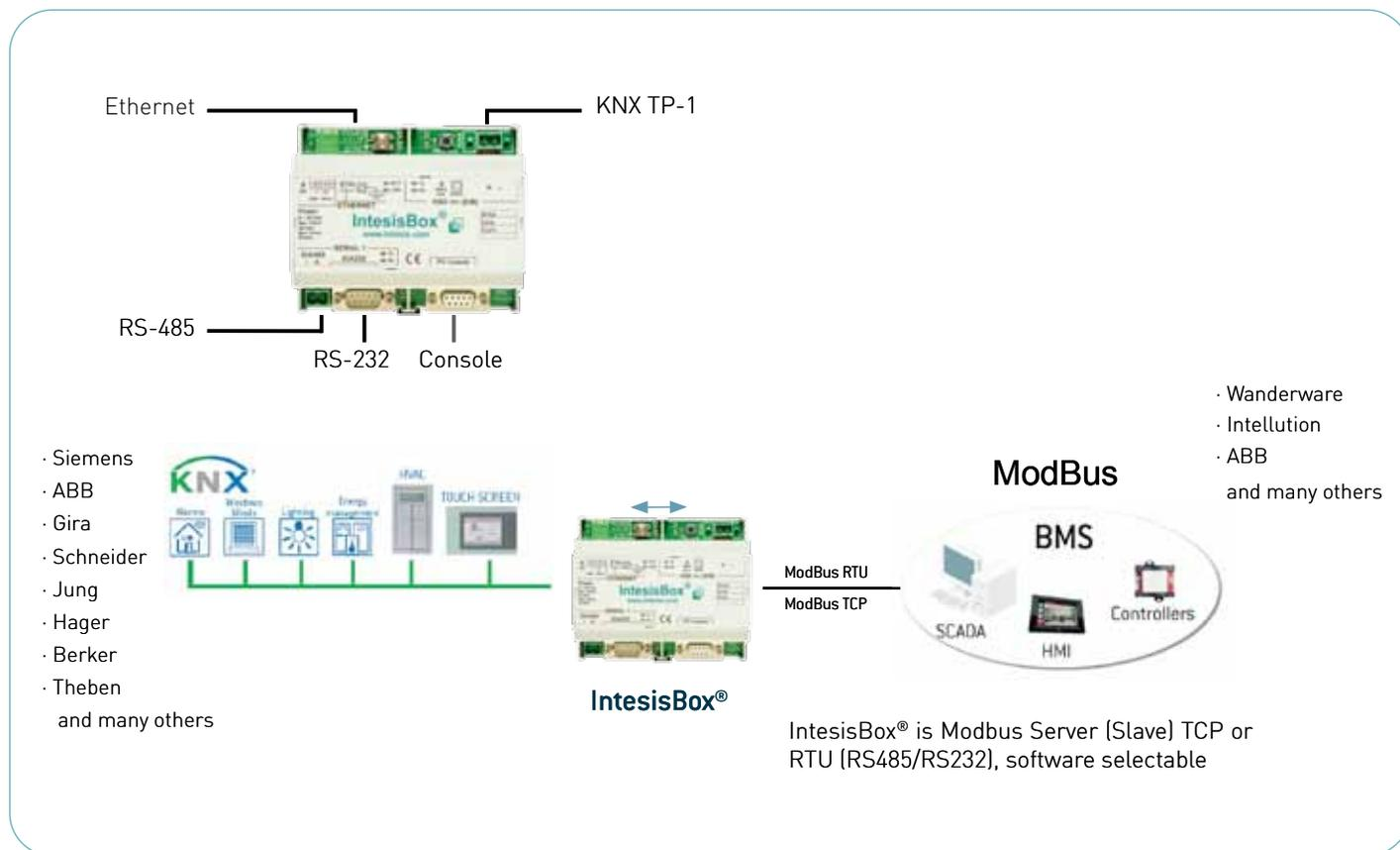

Specifications

- Bidirectional: Monitoring and Control
- Robust and reliable hardware
- Direct connection to KNX and ModBus
- Independent management of communications
- Power supply: 9 to 24Vdc or 24Vac
- Standard DIN-Rail 6 modules enclosure

Models available

- IBOX-MBS-KNX-100 (Maximum 100 control points)
- IBOX-MBS-KNX-A (Maximum 500 control points)
- IBOX-MBS-KNX-B (Maximum 3000 control points)

Info

Datasheet: http://www.intesis.com/pdf/IntesisBox_Modbus_Server_KNX_datasheet_eng.pdf

Main features

- Easy installation. Direct connection to KNX twisted pair bus (TP-1)
- Easy and fast configuration of the ModBus registers with supplied software LinkBoxMB.
- Great integration flexibility. The gateway becomes another device in the KNX system. The ModBus interface supports ModBus TCP or ModBus RTU(RS-232 or RS-485), software selectable, and behaves as a ModBus slave device.
- Advanced integration of KNX installations (light control, blinds, ...) in building management systems based in ModBus (Wanderware, Intellution, ABB, Schneider,...).

IBOX-MBS-MBUS

IntesisBox® IBOX-MBS-MBUS gateway has been specially designed to monitor all the registers of M-BUS meters from ModBus installations.

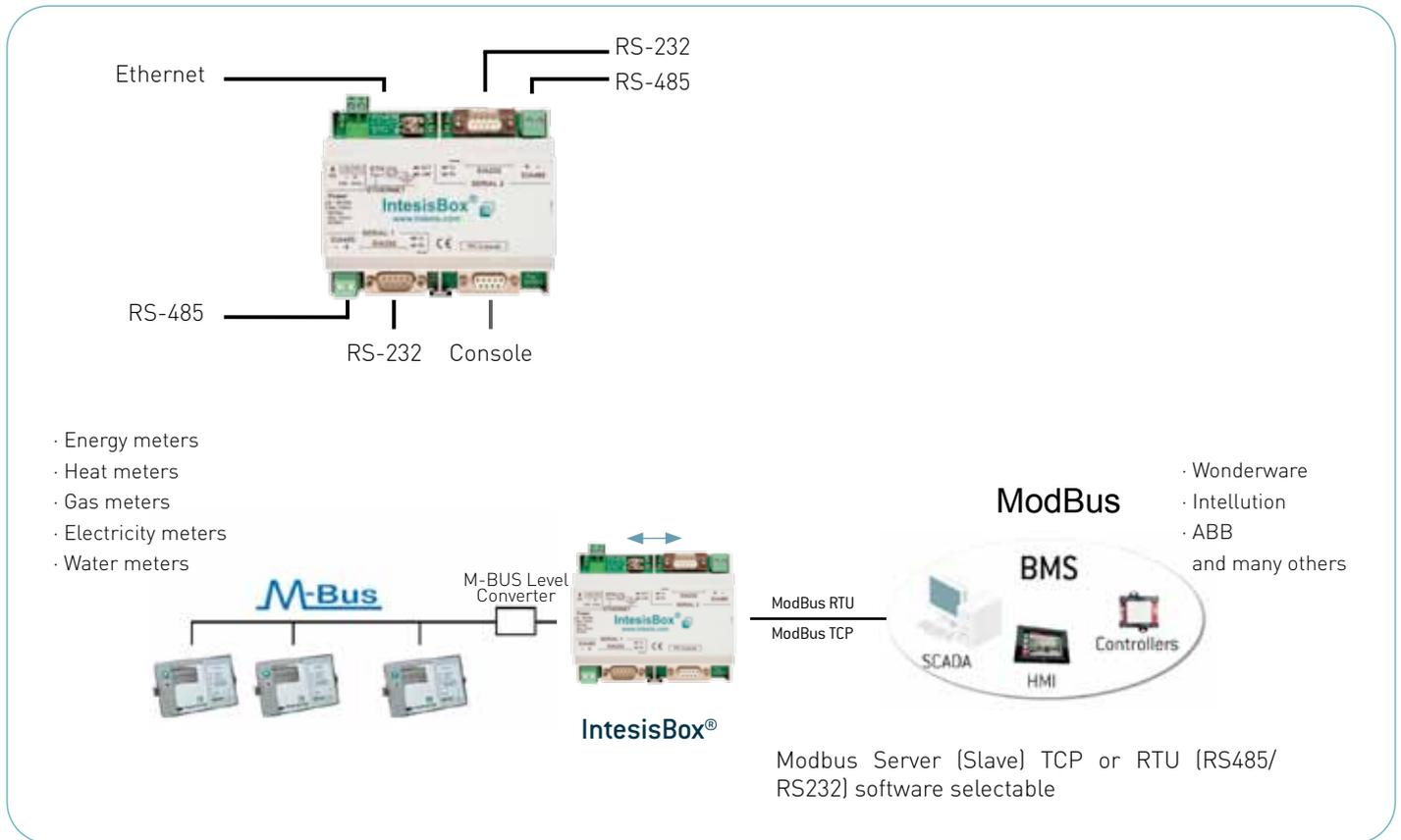

Specifications

- Bidirectional: Monitoring and Control
- Robust and reliable hardware
- Direct connection to ModBus TCP or RTU
- Independent management of communications
- Power supply: 9 to 24Vdc or 24Vac
- Standard DIN-Rail 6 modules enclosure

Models available

- IBOX-MBS-MBUS-100 (Maximum 100 control points and 10 devices)
- IBOX-MBS-MBUS-A (Maximum 600 control points and 60 devices)
- IBOX-MBS-MBUS-B (Maximum 2000 control points and 500 devices)

Info

Datasheet: http://www.intesis.com/pdf/IntesisBox_Modbus_Server_M-Bus_datasheet_eng.pdf

Main features

- Easy installation. Connection to M-Bus system with an external level converter M-Bus RS232 or RS485; at the other side it communicates with the Monitoring/control system with ModBus RTU or TCP protocol.
- Easy and fast configuration of the gateway with supplied software LinkBoxMB.
- Great integration flexibility. The gateway polls continuously or only when ordered from the ModBus master, updating internal memory ready to be read by ModBus master device.
- Advanced integration. Enables full and transparent Monitoring of M-Bus installations (energy meters, gas meters, etc.) from ModBus based BMS systems (Wanderware, Intellution, ABB, Schneider,...).

IBOX-MBS-BAC

IntesisBox® IBOX-MBS-BAC gateway have been specially designed, to allow monitoring and bidirectional control of all the parameters and functionality of systems and devices with BACnet/IP connectivity from ModBus installations.



BACnet devices

HVAC

- Air Conditioners
- Chillers
- thermostats
- Fan-coil controllers
- Automations

Meters

- Electric meters
- Energy meters
- T° and Hr probes

Automation

- B.M.S.
- PLC
- HMI
- and many others

BACnet/IP



IntesisBox®

ModBus RTU

ModBus TCP

Modbus



Modbus Server (Slave) TCP o RTU (RS485/RS232) software selectable

- Wonderware
- Intellution
- ABB
- and many others

Integration example:
AC VRV DAIKIN equipped with BACnet gateway.

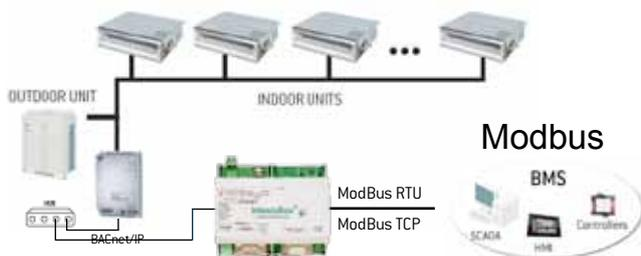

Integration example:
Fan-coil BACnet/IP controllers.

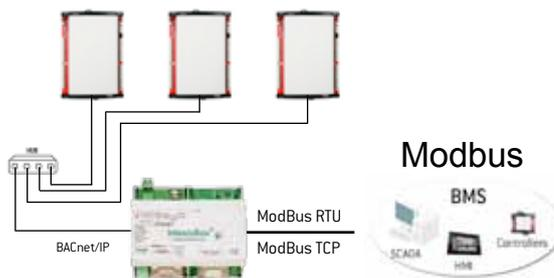

Specifications

- Bidirectional: Monitoring and Control
- Robust and reliable hardware
- Direct connection to BACnet and ModBus
- Independent management of communications
- Power supply: 9 to 24Vdc or 24Vac
- Standard DIN-Rail 6 modules enclosure

Models available

- IBOX-MBS-BAC-100 (Maximum 100 control points and 16 BACnet/IP devices)
- IBOX-MBS-BAC-A (Maximum 500 control points and 16 BACnet/IP devices)
- IBOX-MBS-BAC-B (Maximum 3000 control points and 16 BACnet/IP devices)

Info

Datasheet: http://www.intesis.com/pdf/IntesisBox_Modbus_Server_Bacnet_IP_Client_datasheet_eng.pdf

Main features

- Easy installation. Connection to the BACnet/IP network through Ethernet.
- Great integration flexibility. IntesisBox® IBOX-KNX-BAC is a BACnet/IP client that reads/writes points of other BACnet/IP devices, using continuous polling or subscription (COV). Supports both ModBus TCP or RTU (RS232 or RS485). ModBus registers are configured by supplied software LinkBoxMB.
- Advanced integration for centralized AC systems equipped with BACnet/IP interfaces, as Daikin, Mitsubishi Heavy, LG, etc. also integrating fan-coil controllers, meters, PLC's, HMI, etc.

IBOX-MBS-BACMSTP

IntesisBox® IBOX-MBS-BACMSTP gateway have been specially designed, to allow monitoring and bidirectional control of all the parameters and functionality of systems and devices with BACnet/MSTP connectivity from ModBus installations.

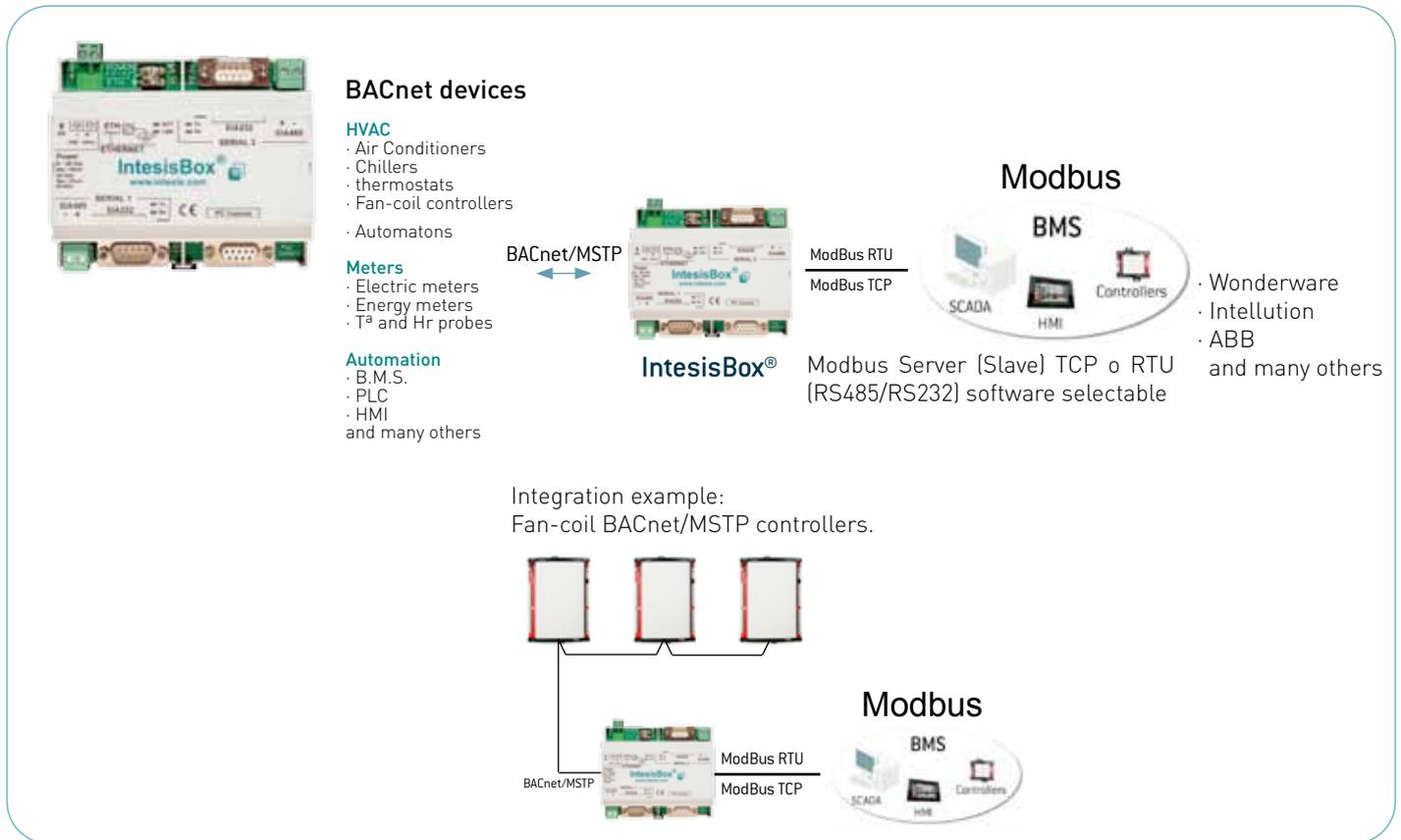

Specifications

- Bidirectional: Monitoring and Control
- Robust and reliable hardware
- Direct connection to BACnet and ModBus
- Independent management of communications
- Power supply: 9 to 24Vdc or 24Vac
- Standard DIN-Rail 6 modules enclosure

Models available

- IBOX-MBS-BACMSTP-100 (100 control points and 64 BACnet/MSTP devices)
- IBOX-MBS-BACMSTP-A (500 control points and 64 BACnet/MSTP devices)
- IBOX-MBS-BACMSTP-B (3000 control points and 64 BACnet/MSTP devices)

Info

Datasheet: http://www.intesis.com/pdf/IntesisBox_Modbus_Server_BACnet_MSTP_datasheet_eng.pdf

Main features

- Easy installation. Direct connection using RS485 (2 wires) to BACnet devices.
- Great integration flexibility. IntesisBox® IBOX-KNX-BACMSTP is a BACnet/IP client that reads/writes points of other BACnet/SMTTP devices connected, using continuous polling or subscription (COV). Supports both ModBus TCP or RTU (RS232 or RS485). ModBus registers are configured by supplied software LinkBoxMB.
- Advanced integration of fan-coil controllers, meters, PLC's, HMI, etc.

IBOX-MBS-LON

IntesisBox® IBOX-MBS-LON gateway has been specially designed to allow monitoring and bidirectional control of all the parameters and functionality of systems and equipment with LonWorks® connectivity from ModBus installations.

LonWorks® devices

HVAC

- Air Conditioners
- Chillers
- thermostats
- Fan-coil controllers
- Automaton

Meters

- Electric meters
- Energy meters
- T³ and Hr probes

Automation

- B.M.S.
- PLC
- HMI
- and many others

LON TP/FT-10



IntesisBox®

ModBus RTU

ModBus TCP

Modbus

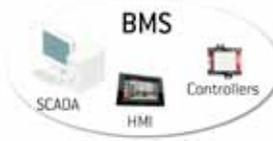

Modbus Server (Slave) TCP or RTU (RS485/RS232) software selectable

- Wonderware
- Intellution
- ABB
- and many others



Integration example:
VRV DAIKIN equipped with LON gateway.

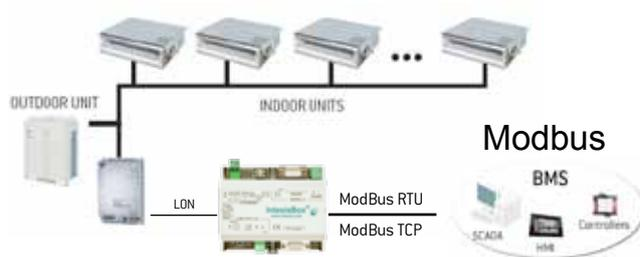

Integration example:
LON Fan-coil controllers.

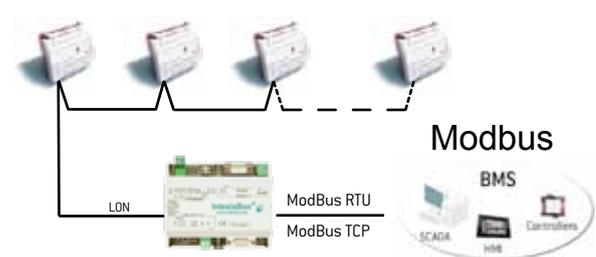

Specifications

- Bidirectional: Monitoring and Control
- Robust and reliable hardware
- Direct connection to LON and ModBus
- Independent management of communications
- Power supply: 9 to 24Vdc or 24Vac
- Standard DIN-Rail 6 modules enclosure

Models available

- IBOX-MBS-LON-100 (Maximum 100 control points and 64 LON devices)
- IBOX-MBS-LON-A (Maximum 500 control points and 64 LON devices)
- IBOX-MBS-LON-B (Maximum 3000 control points and 128 LON devices)

Info

Datasheet: http://www.intesis.com/pdf/IntesisBox_Modbus_Server_LON_datasheet_eng.pdf

Main features

- Easy installation. Direct connection to Lonworks devices with 2 wire (TP/FT-10) connection.
- Great integration flexibility. No bindings needed thanks to continuous polling readout. Access through physical address (Neuron-Id) or subnet node (commissioned devices) possible. LonMaker not required. Supports both ModBus TCP or RTU (RS232 or RS485). ModBus registers are configured by supplied software LinkBoxMB.
- Advanced integration for centralized AC systems equipped with Lonworks interfaces, as Daikin, Mitsubishi Heavy, LG, etc. also integrating fan-coil controllers, meters, PLC's, HMI, etc.

IBOX-MBS-DALI

IntesisBox® IBOX-MBS-DALI gateway has been specially designed to allow monitoring and bidirectional control of DALI ballasts from ModBus installations.

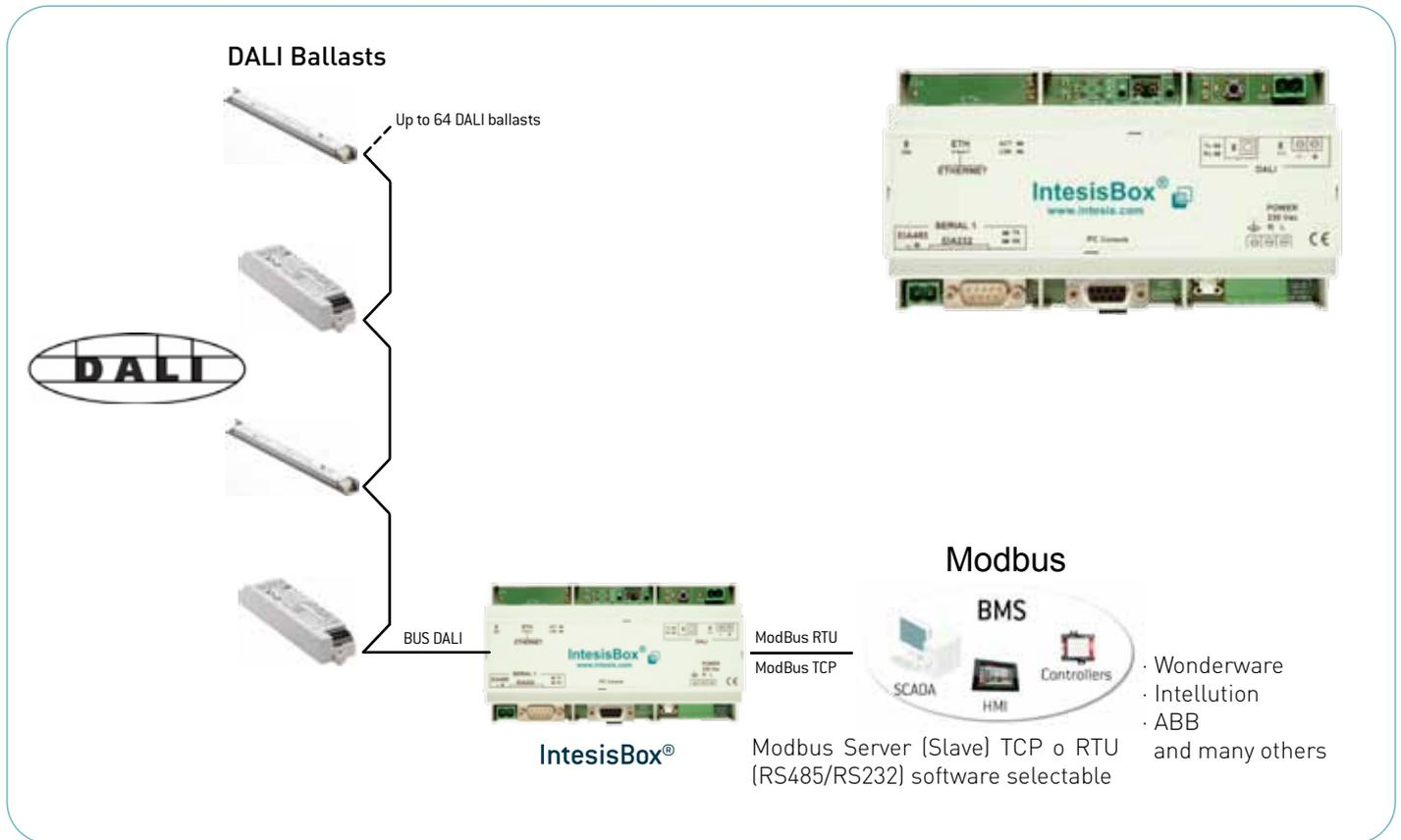

Specifications

- Bidirectional: Monitoring and Control
- Robust and reliable hardware
- Direct connection to DALI and ModBus
- DALI power supplied by the IntesisBox unit
- Mains Power at 230 Vac
- Standard DIN-Rail 9 modules enclosure

Main features

- Easy installation. Direct connection using 2 wires to the DALI ballasts.
- Great integration flexibility. IntesisBox® IBOX-MBS-DALI is a DALI Master that reads/writes ballasts connected to the bus. Supports both ModBus TCP or RTU (RS232 or RS485), acting like ModBus slave device. ModBus registers are configured by supplied software LinkBoxMB.
- Advanced integration of DALI ballasts: digital control of power level (dimming), error condition detections reporting, etc.

Info

Datasheet: http://www.intesis.com/pdf/IntesisBox_Modbus_Server_DALI_datasheet_eng.pdf

IBOX-MBS-ATERSA

IntesisBox® IBOX-MBS-ATERSA gateway has been specially designed to allow monitoring of all the operating parameters of the inverters (CICLO™ AND SIEL-SOLEIL), panels (CSP-12™) and device (DATASOL MET) of ATERSA, from any ModBus installation.

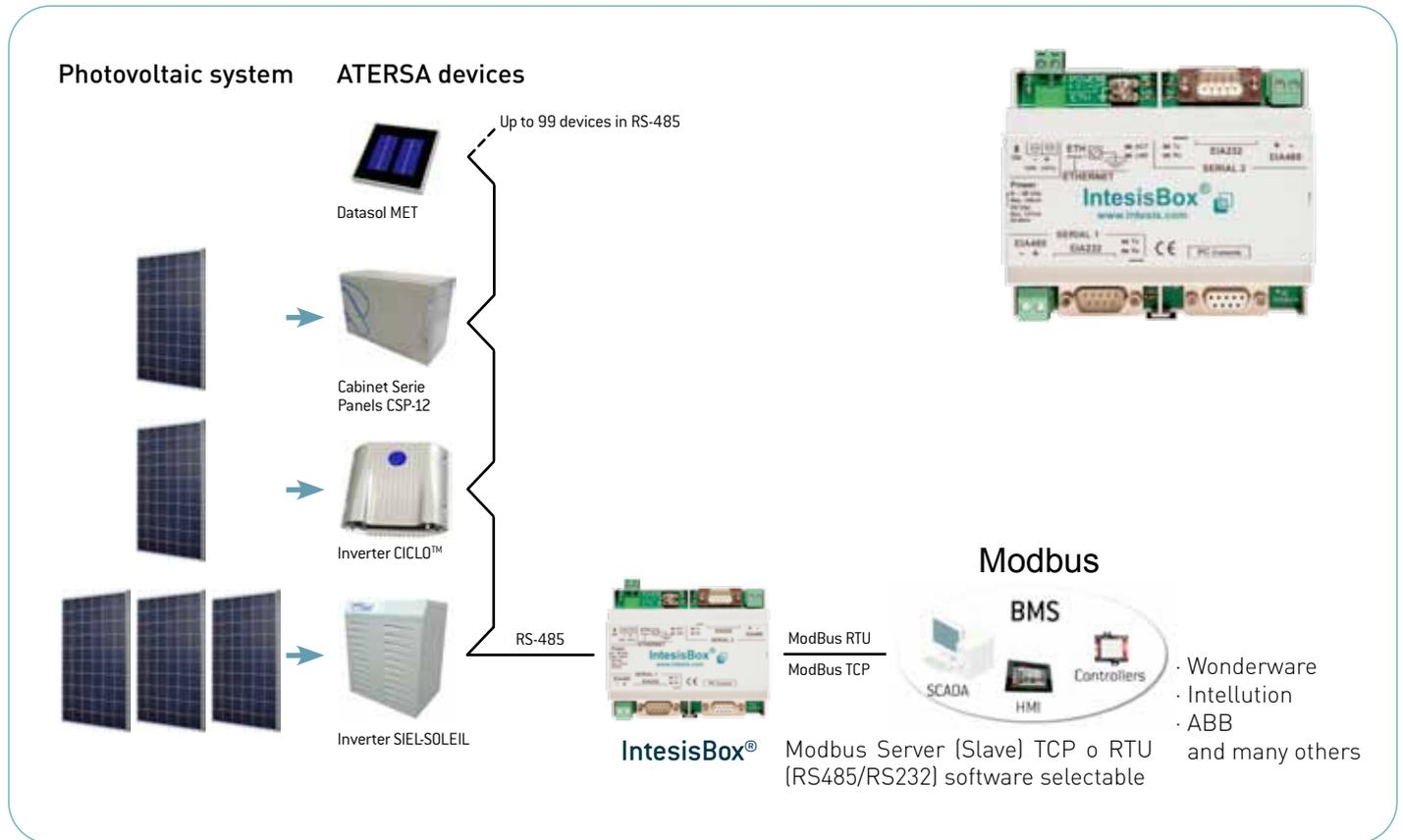

Specifications

- Bidirectional: Monitoring and Control
- Robust and reliable hardware
- Direct connection to RS485 and ModBus
- Independent management of communications
- Power supply: 9 to 24Vdc or 24Vac
- Standard DIN-Rail 6 modules enclosure

Main features

- Easy installation. Direct connection using 2 wires (RS485) to ATERSA devices.
- Great integration flexibility. IntesisBox® ATERSA reads continuously by polling ATERSA devices making read values available when needed. IBOX-MBS-ATERSA shows ATERSA devices as ModBus slave. Supports both ModBus TCP or RTU (RS232 or RS485), acting as ModBus slave.
- Advanced integration of the photovoltaic collection system with ATERSA devices in any control system based in ModBus protocol, like Wonderware, Intellution, ABB, etc

Info

Datasheet: http://www.intesis.com/pdf/IntesisBox_Modbus_Server_Atersa_datasheet_eng.pdf

IBOX-MBS-FIDELIO_IP

IntesisBox® IBOX-MBS-FIDELIO gateway has been specially designed to offer monitoring of MICROS FIDELIO hotel management systems from ModBus installations.



Fidelio hotel management system

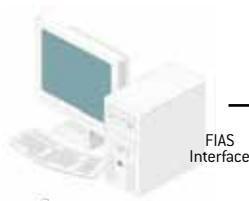

ETHERNET

FIAS Interface



IntesisBox®

ModBus RTU
ModBus TCP

Modbus



Modbus Server (Slave) TCP o RTU (RS485/RS232), software selectable

- Wonderware
- Intellution
- ABB
- and many others

Supervision of Check IN/Check OUT states, up to 1.500 rooms.

Specifications

- Robust and reliable hardware
- Direct connection to ModBus
- Independent management of communications
- Power supply: 9 to 24Vdc or 24Vac
- Standard DIN-Rail 6 modules enclosure

Main features

- Easy installation. Ethernet connection to the Fidelio system through FIAS communication interface.
- Fidelio IntesisBox unit read values check in/out states up to 1500 rooms. Read values kept in IntesisBox® memory to be used when needed by the ModBus system. Supports both ModBus TCP or RTU (RS232 or RS485), acting as ModBus slave. ModBus registers are configured by supplied software LinkBoxMB.
- Advanced integration of Fidelio hotel management in any ModBus based system, like Wonderware, Intellution, ABB and many more.

Info

Datasheet: http://www.intesis.com/pdf/IntesisBox_Modbus_Server_Fidelio_datasheet_eng.pdf

IBOX-MBS-TCP2RTU

IntesisBox® IBOX-MBS-TCP2RTU gateway has been specially designed to offer monitoring and bidirectional control of all the parameters and functionality of systems and devices with ModBus RTU Slave connectivity from ModBus TCP Masters.

Modbus RTU Slave devices

HVAC

- Air Conditioners
- Chillers
- thermostats
- Fan-coil controllers
- Automotons

Meters

- Electric meters
- Energy meters
- T° and Hr probes

Automation

- B.M.S.
- PLC
- HMI

and many others

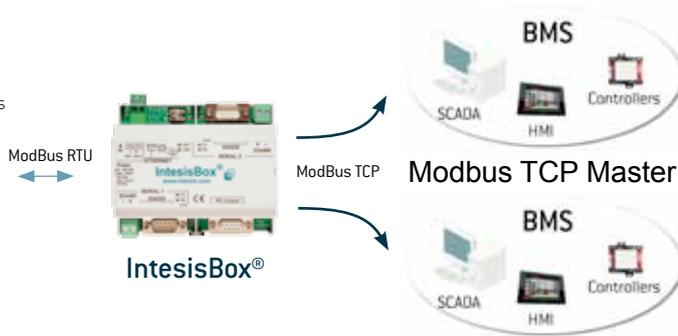

Integration example:
Chillers with ModBus RTU.

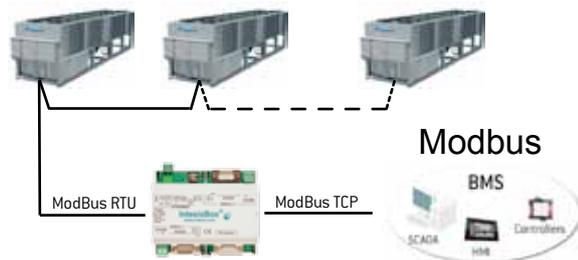

Integration example:
ModBus RTU electric meters.

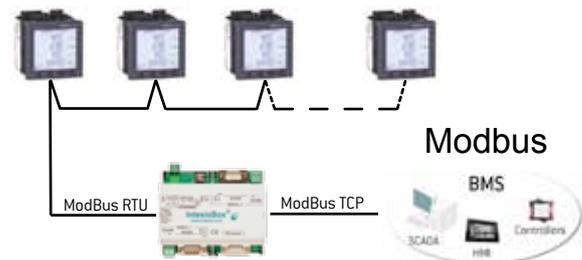

Specifications

- Bidirectional: Monitoring and Control
- Robust and reliable hardware
- Direct connection to ModBus RTU and TCP
- Independent management of communications
- Power supply: 9 to 24Vdc or 24Vac
- Standard DIN-Rail 6 modules enclosure

Models available

- IBOX-MBS-TCP2RTU (254 ModBus RTU Slave devices / 32 ModBus TCP Master devices)

Main features

- Easy installation. Direct connection trough RS-485 or RS-232 bus to the ModBus RTU Slave devices.
- Great integration flexibility. Access to ModBus RTU devices from ModBus TCP. Several ModBus TCP Master devices can access the same ModBus RTU devices. ModBus TCP communication frames are converted to ModBus RTU, and vice versa, transparently. Simple configuration using supplied LinkBoxMB software. ModBus TCP connection acts like a slave and the ModBus RTU acts like a master.
- Advanced integration for HVAC systems equipped with ModBus RTU interface in ModBus TCP installations, like Daikin, Ciatesa, Hitecsa, etc. Also integrate in ModBus RTU fan-coil controllers, meters, PLC's, HMI, etc.

Info

Datasheet: http://www.intesis.com/pdf/IntesisBox_MBS_TCP2RTU_datasheet_eng.pdf

IBOX-MBS-4SLAVE

IntesisBox® IBOX-MBS-4SLAVE gateway has been specially designed to offer data sharing of up to 4 ModBus Master devices between themselves.

Integration examples:

Integration of 2 Modbus TCP Master and 2 Modbus RTU Master.

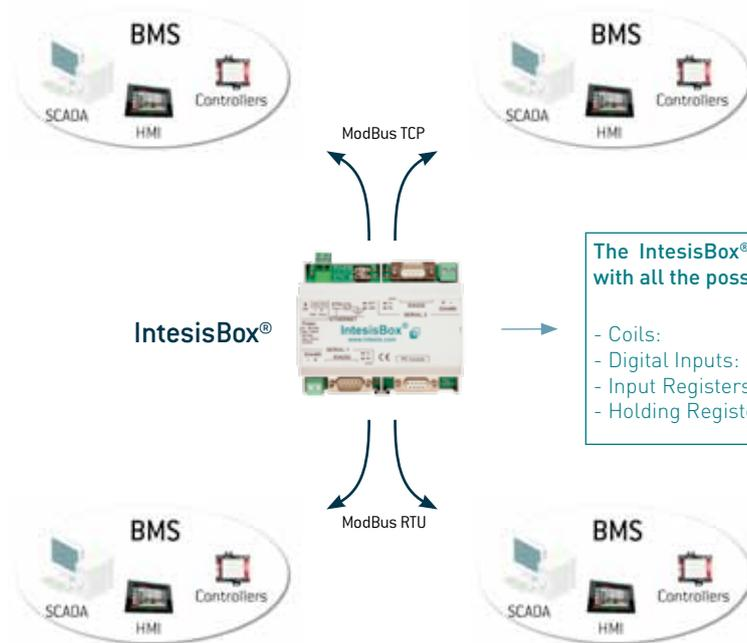

The IntesisBox® IBOX-MBS-4SLAVE has a complete Modbus map with all the possible Modbus registers as specified:

- Coils: 0..65535 (100001..165536)
- Digital Inputs: 0..65535 (200001..265536)
- Input Registers: 0..65535 (300001..365536)
- Holding Registers: 0..65535 (400001..465536)

Specifications

- Bidirectional
- Robust and reliable hardware
- Direct connection with ModBus TCP and RTU
- Independent management of communications
- Power supply: 9 to 24Vdc or 24Vac
- Standard DIN-Rail 6 modules enclosure

Models available

- IBOX-MBS-4SLAVE (Maximum 2 ModBus RTU Master devices and 2 ModBus TCP Master devices simultaneously.)

Main features

- Easy installation. IBOX-MBS-4SLAVE has 2 ModBus RTU SLAVE (RS-232/RS-485) ports and Modbus TCP Slave (for 2 ModBus TCP Master devices) port.
- Great integration flexibility. Allows exchange of register values from up to 4 ModBus Master devices sharing the memory map from one slave device, where all of them write and read. Simple configuration using supplied LinkBoxMB software. Both ModBus TCP and RTU act as slaves.
- Advanced integration. Allows integrating ModBus installations without ModBus Master devices limitations. Ability to exchange information between 2, 3 and 4 independent ModBus installations.

Info

Datasheet: http://www.intesis.com/pdf/IntesisBox_MBS_4SLAVE_datasheet_eng.pdf

FIRE & SECURITY PANELS INTEGRATION

IntesisBox® product family includes a range of specially designed gateways to offer monitoring of fire and security panels from BMS systems based in ModBus of most important manufacturers in this industry.

Integration	Intesis gateway	Panel manufacturer	Panel models
FIRE	IBOX-MBS-CERBERUS	SIEMENS	Cerberus CS11 and CS10, with the ISO 1745 protocol
	IBOX-MBS-FC330A	SIEMENS	Synova® FC330A
	IBOX-MBS-ALGOREX	SIEMENS	Algorex
	IBOX-MBS-ALGORI	ADEMCO	Algorinet BC216
	IBOX-MBS-ESSER	ESSER	8007/8008 and IQ8,
	IBOX-MBS-KILSEN	KILSEN	KSA 7XX
	IBOX-MBS-ZITON	ZITON	ZP3 and ZP5
	IBOX-MBS-NID3000	NOTIFIER	ID3000 and ID3002
	IBOX-MBS-ID2NET	NOTIFIER	Up to 64 fire panels Notifier ID3000 in ID2NET network
	IBOX-MBS-XLS80	HONEYWELL	XLS-80
SECURITY	IBOX-MBS-GALAXY	HONEYWELL	Galaxy

Integration	Intesis gateway	Datasheet download
FIRE	IBOX-MBS-CERBERUS	http://www.intesis.com/pdf/IntesisBox_Modbus_Server_Cerberus_ISO1745_datasheet_eng.pdf
	IBOX-MBS-FC330A	http://www.intesis.com/pdf/IntesisBox_Modbus_Server_FC330A_datasheet_eng.pdf
	IBOX-MBS-ALGOREX	http://www.intesis.com/pdf/IntesisBox_Modbus_Server_Algorex_datasheet_eng.pdf
	IBOX-MBS-ALGORI	http://www.intesis.com/pdf/IntesisBox_Modbus_Server_Algorinet_datasheet_eng.pdf
	IBOX-MBS-ESSER	http://www.intesis.com/pdf/IntesisBox_Modbus_Server_ESSER_datasheet_eng.pdf
	IBOX-MBS-KILSEN	http://www.intesis.com/pdf/IntesisBox_Modbus_Server_KILSEN_datasheet_eng.pdf
	IBOX-MBS-ZITON	http://www.intesis.com/pdf/IntesisBox_Modbus_Server_ZITON_datasheet_eng.pdf
	IBOX-MBS-NID3000	http://www.intesis.com/pdf/IntesisBox_Modbus_Server_NID3000_datasheet_eng.pdf
	IBOX-MBS-ID2NET	http://www.intesis.com/pdf/IntesisBox_Modbus_Server_NID2Net_datasheet_eng.pdf
	IBOX-MBS-XLS80	http://www.intesis.com/pdf/IntesisBox_Modbus_Server_XLS80_datasheet_eng.pdf
SECURITY	IBOX-MBS-GALAXY	http://www.intesis.com/pdf/IntesisBox_Modbus_Server_Galaxy_datasheet_eng.pdf



BACNET



IntesisBox

products for BACnet systems



BACnet is the Data Communication Protocol for Building Automation and Control Networks. Developed under the auspices of the American Society of Heating, Refrigerating and Air-Conditioning Engineers (ASHRAE), BACnet is an American national standard, a European standard, a national standard in more than 30 countries, and an ISO global standard. The protocol is supported and maintained by ASHRAE Standing Standard Project Committee 135.

For further information, please visit www.bacnet.org

IntesisBox BACnet gateway

IntesisBox® IBOX-BAC-XXX gateways have been specially designed to allow supervision and bidirectional control of all the parameters and functionality of systems and equipment with KNX, ModBus, LonWorks and Fidelio systems from BACnet/IP networks.

- Easy installation through TP (TP-1/FT-10), RS485, Ethernet or FIAS communication interfaces
- Great integration flexibility
- Advanced integration of KNX (light, control, blinds), Modbus and Lonworks (AC units) in BMS systems including Siemens, Honeywell, Trend, Delta Controls ... and also meters, PLC's, HMI, etc.

BACNET

PA-AC-BAC-64/128

IntesisBox® PA-AC-BAC-64 / 128 gateways have been specially designed, in collaboration with Panasonic, to allow monitoring and bidirectional control of all the parameters and functionality of Panasonic air conditioning ECOi and PACi indoor units from BACnet installations.

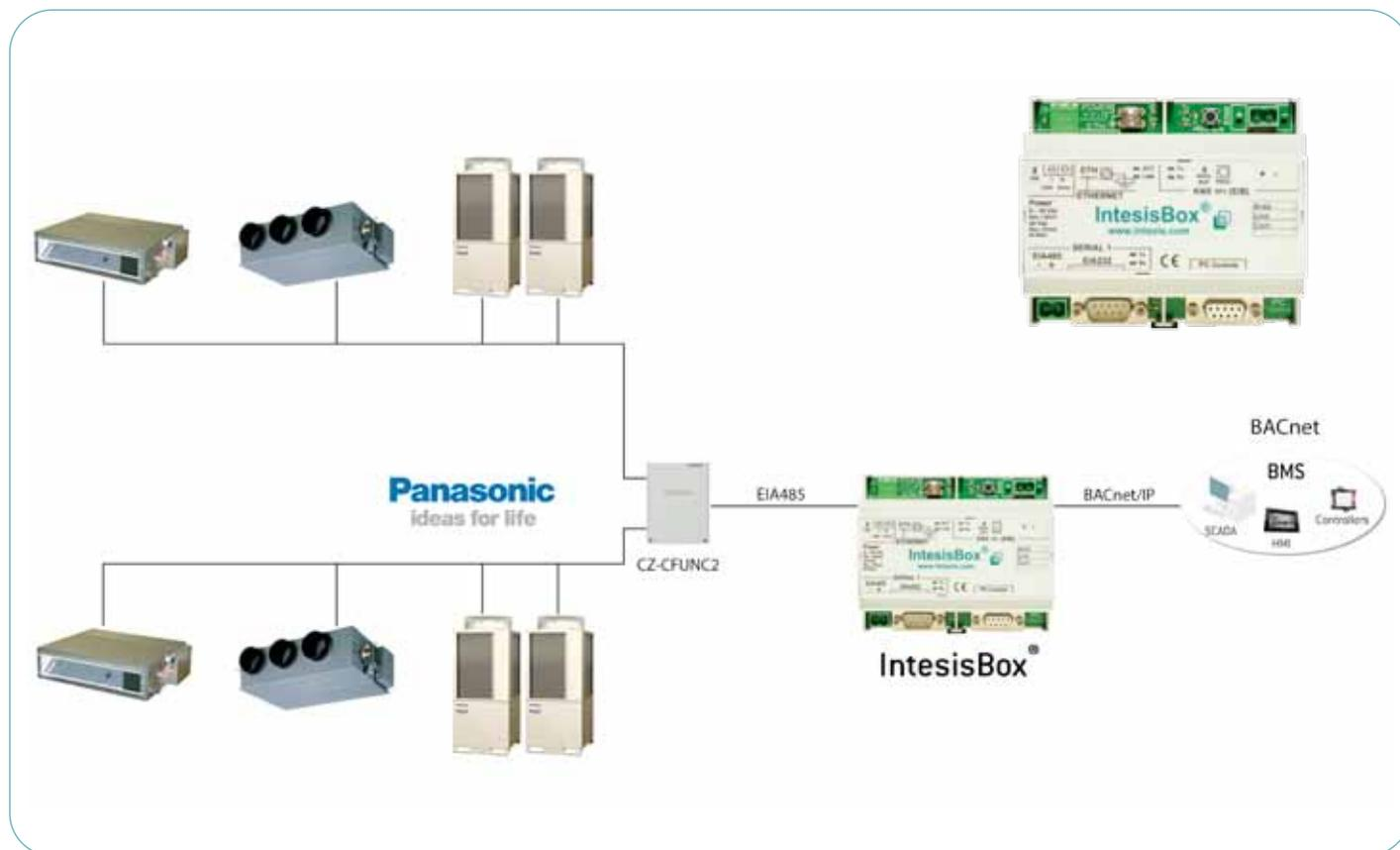

Specifications

- Bidirectional: Monitoring and Control
- Robust and reliable hardware
- Direct connection to BACnet/IP
- Independent management of communications
- Power supply: 9 to 24Vdc or 24Vac
- Standard DIN-Rail 6 modules enclosure

Models available

- PA-AC-BAC-64 (64 indoor units and 30 outdoor units)
- PA-AC-BAC-128 (128 indoor units and 30 outdoor units)

Main features

- Easy installation. Connection of PANASONIC communication interface CZ-CFUNC2 to IntesisBox® through EIA485.
- Great integration flexibility. The gateway polls continuously or by means of BACnet subscription requests (COV). Panasonic indoor units can be monitored and controlled from BACnet using standard BACnet objects. IntesisBox BACnet/IP Server series are configured using LinkBoxBacnet software.
- Simultaneous control from BACnet/IP BMS and the Panasonic remote controller.

Info

Datasheet: http://www.intesis.com/pdf/IntesisBox_PA-AC-BAC-64-128_datasheet_eng.pdf

IBOX-BAC-KNX

IntesisBox® IBOX-BAC-KNX gateway has been specially designed to allow monitoring and bidirectional control of KNX systems from BACnet/IP installations.

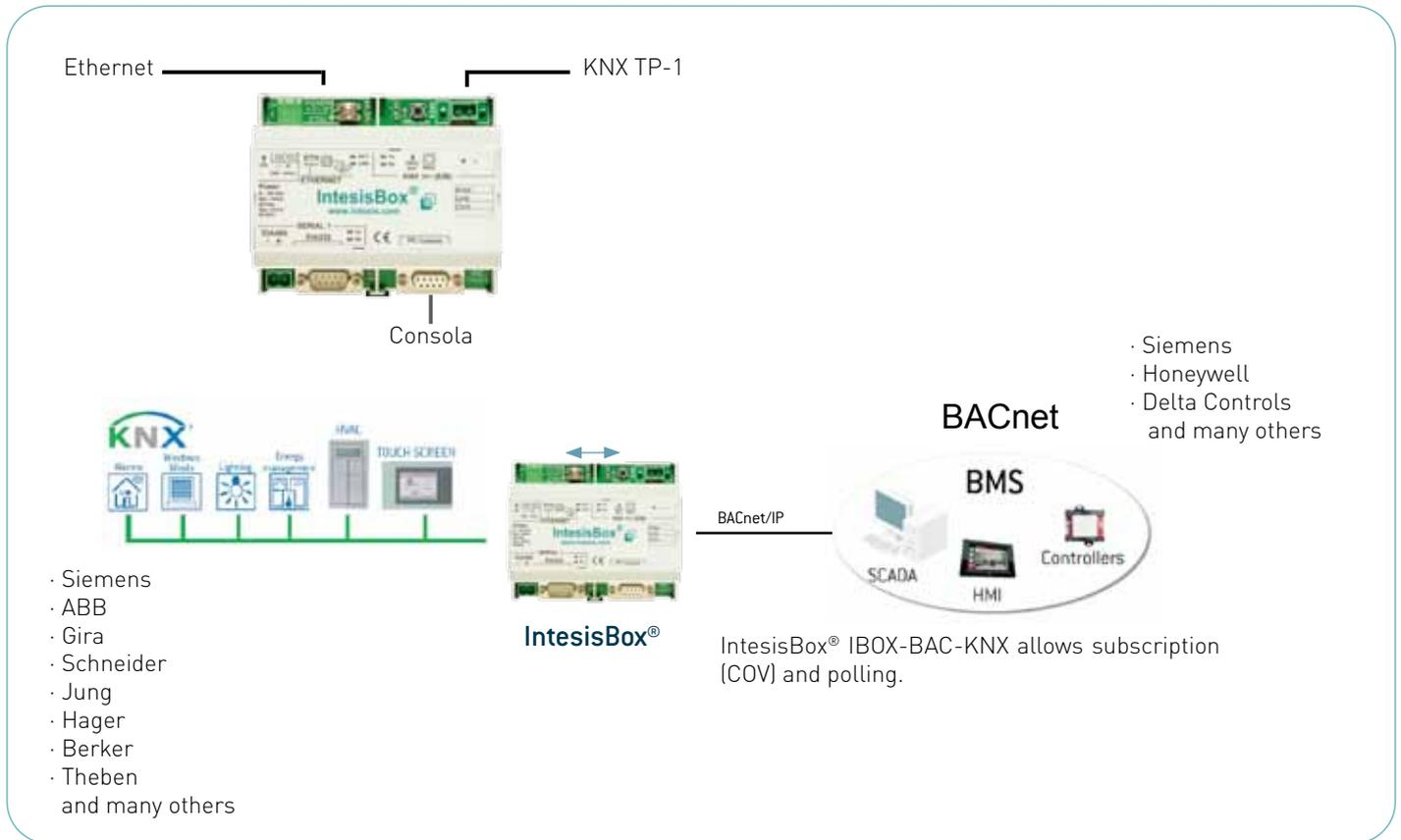

Specifications

- Bidirectional: Monitoring and Control
- Robust and reliable hardware
- Direct connection to KNX and BACnet/IP network
- Independent management of communications
- Power supply: 9 to 24Vdc or 24Vac
- Standard DIN-Rail 6 modules enclosure

Models available

- IBOX-BAC-KNX-100 (Maximum 100 control points)
- IBOX-BAC-KNX-A (Maximum 500 control points)
- IBOX-BAC-KNX-B (Maximum 3000 control points)

Info

Datasheet: http://www.intesis.com/pdf/IntesisBox_BACnet_IP_Server_KNX_datasheet_eng.pdf

Main features

- Easy installation. Direct connection to KNX twisted pair bus (TP-1)
- Easy and fast configuration with supplied software LinkBoxBAC.
- Great integration flexibility. The gateway is a BACnet/IP server. Reading done either by continuous polling or using subscription (COV). BACnet server series are configured with supplied software LinkBoxBAC.
- Advanced integration of KNX installations (light control, blinds, ...) in building management systems based in BACnet/IP (Siemens, Honeywell, Delta Controls, Trend, etc).

IBOX-BAC-MBRTU / IBOX-BAC-MBTCP

IntesisBox® IBOX-BAC-MBRTU / MBTCP gateways have been specially designed to offer monitoring and bidirectional control for all the parameters and functionality of systems and equipment with ModBus connectivity from BACnet/IP installations.

Modbus devices

HVAC

- Air Conditioners
- Chillers
- thermostats
- Fan-coil controllers
- Automotons

Meters

- Electric meters
- Energy meters
- T^a and Hr probes

Automation

- B.M.S.
- PLC
- HMI
- and many others

ModBus RTU
ModBus TCP



IntesisBox®

BACnet/IP

BACnet



- Siemens
- Honeywell
- Delta Controls
- and many others



IntesisBox® IBOX-BAC-MBRTU/ MBTCP gateway can be read by subscription (COV) and polling.

Integration example:
Chillers with Modbus RTU.

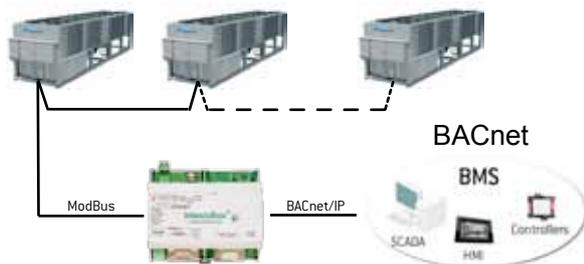

Integration example:
ModBus RTU electricity meters.

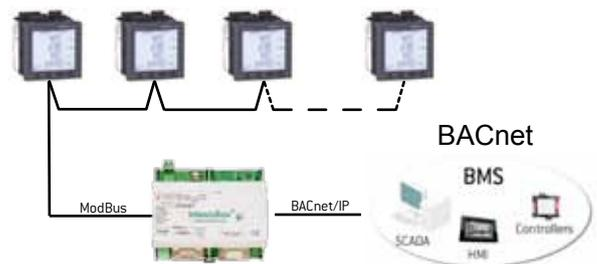

Specifications

- Bidirectional: Monitoring and Control
- Robust and reliable hardware
- Direct connection to ModBus
- Independent management of communications
- Power supply: 9 to 24Vdc or 24Vac
- Standard DIN-Rail 6 modules enclosure

Models available

- IBOX-BAC-MBRTU-100 (Max. 100 control points / 254 ModBus RTU slave devices)
- IBOX-BAC-MBRTU-A (Max. 500 control points / 254 ModBus RTU slave devices)
- IBOX-BAC-MBRTU-B (Max. 3000 control points / 254 ModBus RTU slave devices)
- IBOX-BAC-MBTCP-100 (Max. 100 control points / 6 ModBus TCP slave devices)

Info

Datasheet: http://www.intesis.com/pdf/IntesisBox_BACnet_IP_server_Modbus_RTU_master_datasheet_eng.pdf

Datasheet: http://www.intesis.com/pdf/IntesisBox_BACnet_IP_server_Modbus_TCP_master_datasheet_eng.pdf

- IBOX-BAC-MBTCP-A (Maxi. 500 control points / 6 ModBus TCP slave devices)
- IBOX-BAC-MBTCP-B (Max. 3000 control points / 6 ModBus TCP slave devices)

Main features

- Easy installation. Direct connection to ModBus devices through RS485 (2 wire) (IBOX-BAC-MBRTU) and Ethernet (IBOX-BAC-MBTCP).
- Great integration flexibility. The IntesisBox® ModBus Master interface reads continuously by polling the configured ModBus slave devices. Read values kept in IntesisBox® memory to be used when needed by the BACnet/IP system. Reads done by polling or subscription (COV).
- Advanced integration of HVAC systems with Modbus interface from BACnet/IP like Ciatesa, Hitecsa, Lennox, Carrier, etc. and meters, PLC's , HMI, etc.

IBOX-BAC-LON

IntesisBox® IBOX-BAC-LON gateway has been specially designed to allow monitoring and bidirectional control of all the parameters and functionality of systems and equipment with LonWorks® connectivity from BACnet/IP installations.

LonWorks® devices

HVAC

- Air Conditioners
- Chillers
- thermostats
- Fan-coil controllers

Meters

- Electric meters
- Energy meters
- T^a and Hr probes

Automation

- B.M.S.
- PLC
- HMI
- and many others

LON TP/FT-10



IntesisBox®

BACnet/IP

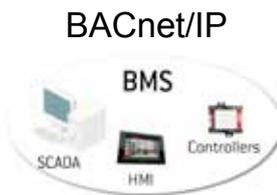

IntesisBox® IBOX-BAC-LON gateway can be read by subscription (COV) and polling.

- Wonderware
- Intellution
- ABB
- and many others



Integration example:
VRV DAIKIN equipped with LON gateway.

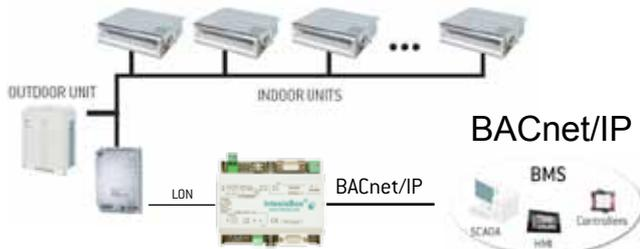

Integration example:
LON Fan-coil controllers.

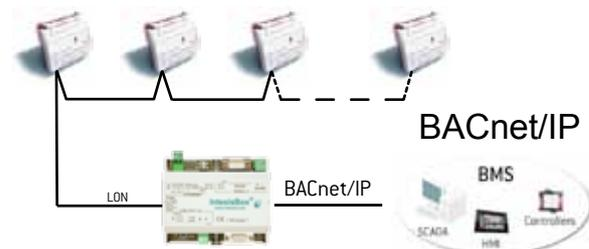

Specifications

- Bidirectional: Monitoring and Control
- Robust and reliable hardware
- Direct connection to LON and BACnet/IP
- Independent management of communications
- Power supply: 9 to 24Vdc or 24Vac
- Standard DIN-Rail 6 modules enclosure

Models available

- IBOX-BAC-LON-100 (Maximum 100 control points and 64 LON devices)
- IBOX-BAC-LON-A (Maximum 500 control points and 64 LON devices)
- IBOX-BAC-LON-B (Maximum 3000 control points and 128 LON devices)

Info

Datasheet: http://www.intesis.com/pdf/IntesisBox_BACnet_IP_Server_LON_datasheet_eng.pdf

Main features

- Easy installation. Direct connection to LONWorks devices through TP/FT-10 (2 wire) connection
- Great integration flexibility. Thanks to LinkBoxBAC supplied software. No bindings needed thanks to continuous polling readout. Access through physical address (Neuron-Id) or subnet node (commissioned devices) possible. LonMaker not required.
- Advanced integration for centralized AC systems equipped with Lonworks interfaces in BACnet/IP (Siemens, Honeywell, Delta Controls, Trend,...), also integrating fan-Coil controllers, meters, PLCs, HMI, etc.

IBOX-BAC-FIDELIO_IP

IntesisBox® IBOX-BAC-FIDELIO gateway has been specially designed to offer monitoring of MICROS FIDELIO hotel management systems from BACnet/IP installations.



Fidelio hotel management system



FIAS Interface

ETHERNET



IntesisBox®

BACnet/IP

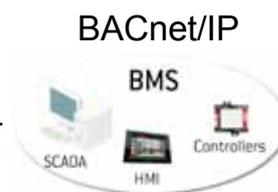

- Siemens
- Honeywell
- Delta Controls
- and many others

Supervision of Check IN/Check OUT states up to 1.500 rooms.

IntesisBox® IBOX-BAC-FIDELIO gateway can be read by subscription (COV) and polling.

Specifications

- Bidirectional: Monitoring and Control
- Robust and reliable hardware
- Direct connection to BACnet/IP
- Independent management of communications
- Power supply: 9 to 24Vdc or 24Vac
- Standard DIN-Rail 6 modules enclosure

Main features

- Easy installation. Connection trough Ethernet to the Fidelio system through the FIAS communication interface.
- Great integration flexibility. IntesisBox® FIDELIO read values check IN/OUT states up to 1500 rooms. Read values kept in IntesisBox® memory to be used when needed by the BACnet/IP system. Reads in BACnet/IP side done by polling or subscription (COV). IntesisBox BACnet/IP gateways are configured by supplied software LinkBoxBAC.
- Advanced integration of Fidelio hotel management in any BACnet/IP based system , like Siemens, Honeywell, delta Controls, Trend , ...]

Info

Datasheet: http://www.intesis.com/pdf/IntesisBox_BACnet_IP_Server_Fidelio_datasheet_eng.pdf

IBOX-BAC-MBUS

IntesisBox® IBOX-BAC-MBUS gateway has been specially designed to monitor all the registers of M-BUS meters from BACnet/IP installations.

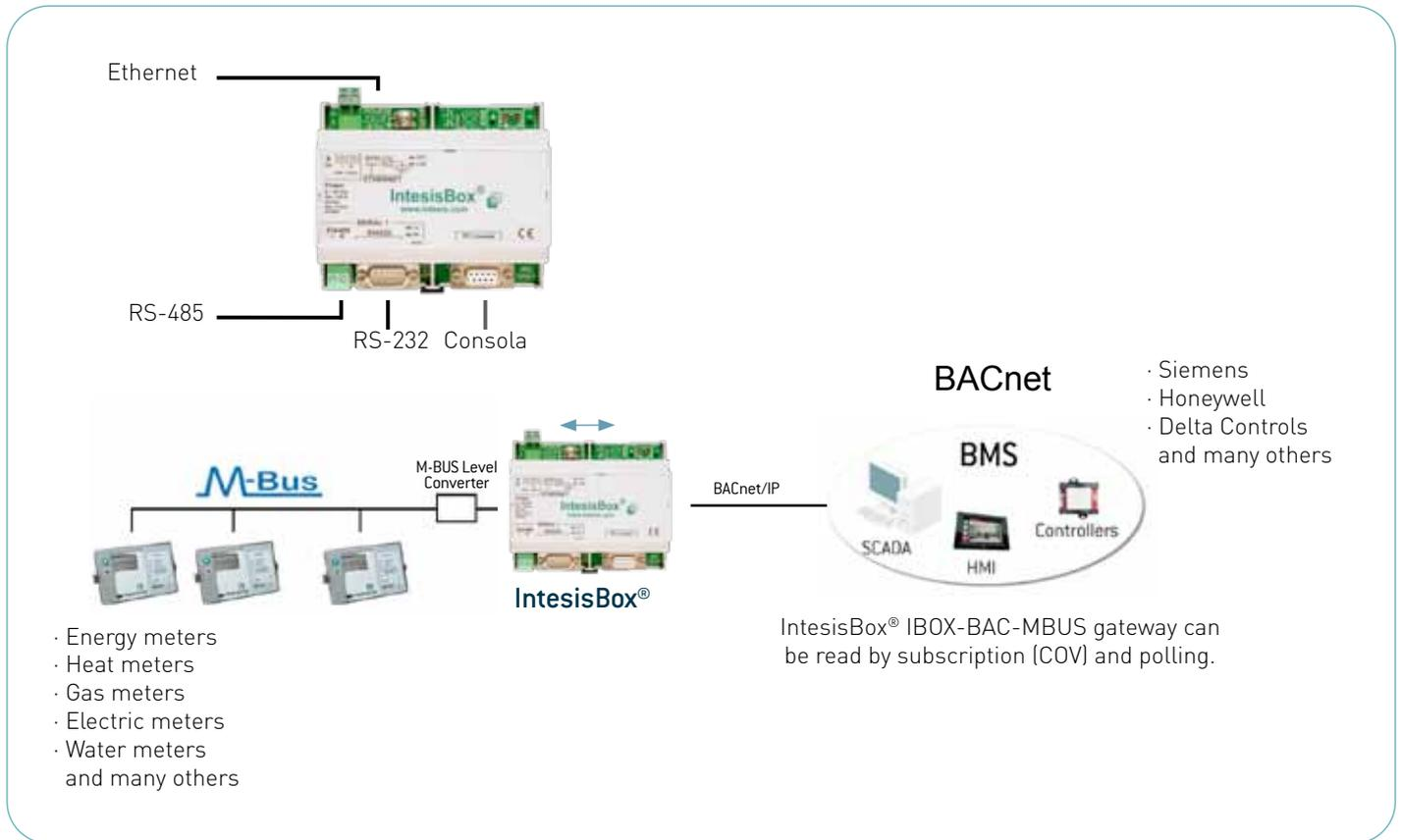

Specifications

- Bidirectional: Monitoring and Control
- Robust and reliable hardware
- Direct connection to BACnet/IP
- Independent management of communications
- Power supply: 9 to 24Vdc or 24Vac
- Standard DIN-Rail 6 modules enclosure

Models available

- IBOX-BAC-MBUS-100 (Maximum 100 control points and 10 devices)
- IBOX-BAC-MBUS-A (Maximum 600 control points and 60 devices)
- IBOX-BAC-MBUS-B (Maximum 2000 control points and 500 devices)

Info

Datasheet: http://www.intesis.com/pdf/IntesisBox_BACnet_IP_server_M-Bus_datasheet_eng.pdf

Main features

- Easy installation. Connection to M-Bus system with an external level converter M-Bus RS232 or RS485; at the other side it communicates with the Monitoring/control system with BACnet/IP protocol.
- Easy and fast configuration of the gateway with supplied software LinkBoxBAC.
- Great integration flexibility. The gateway polls continuously or only when ordered from the BACnet/IP side, updating internal memory ready to be read by polling or subscription from the BACnet/IP side.
- Advanced integration. Enables full and transparent Monitoring of M-Bus installations (energy meters, gas meters, etc.) from BACnet/IP based BMS systems (Siemens, Honeywell, Delta Controls, Trend ...).

IBOX-BAC-DALI

IntesisBox® IBOX-BAC-DALI gateway has been specially designed to allow monitoring and bidirectional control of DALI ballasts from BACnet/IP installations.

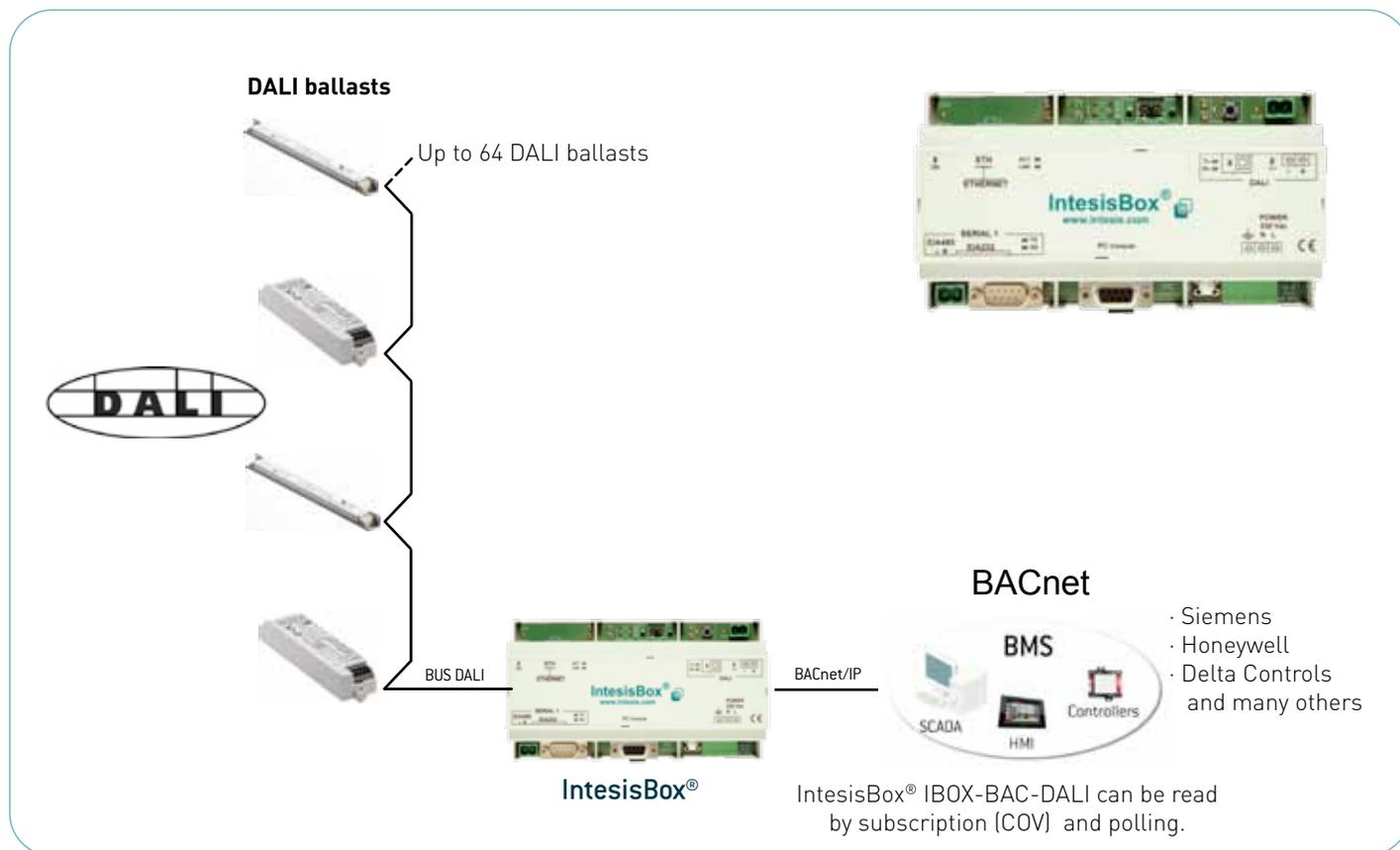

Specifications

- Bidirectional: Monitoring and Control
- Robust and reliable hardware
- Up to 64 DALI ballasts integration
- Direct connection to DALI and BACnet/IP
- DALI power supply included
- Mains Power at 230 Vac
- Standard DIN-Rail 9 modules enclosure

Main features

- Easy installation. Direct connection using 2 wires to the DALI ballasts.
- Great integration flexibility. IntesisBox® IBOX-BAC-DALI is a DALI Master that reads/writes ballasts connected to the bus. IntesisBox BACnet server gateways are configured by supplied software LinkBoxBAC.
- Advanced integration of DALI ballasts: digital control of power level (dimming), error condition detections reporting, etc.

Info

Datasheet: http://www.intesis.com/pdf/IntesisBox_BACnet_IP_Server_DALI_datasheet_eng.pdf

IBOX-BAC-SUNWAYS

IntesisBox® IBOX-BAC-SUNWAYS gateway has been specially designed to allow monitoring of all the operating parameters of SUNWAYS NT Series inverters (photovoltaic) from any BACnet installation.

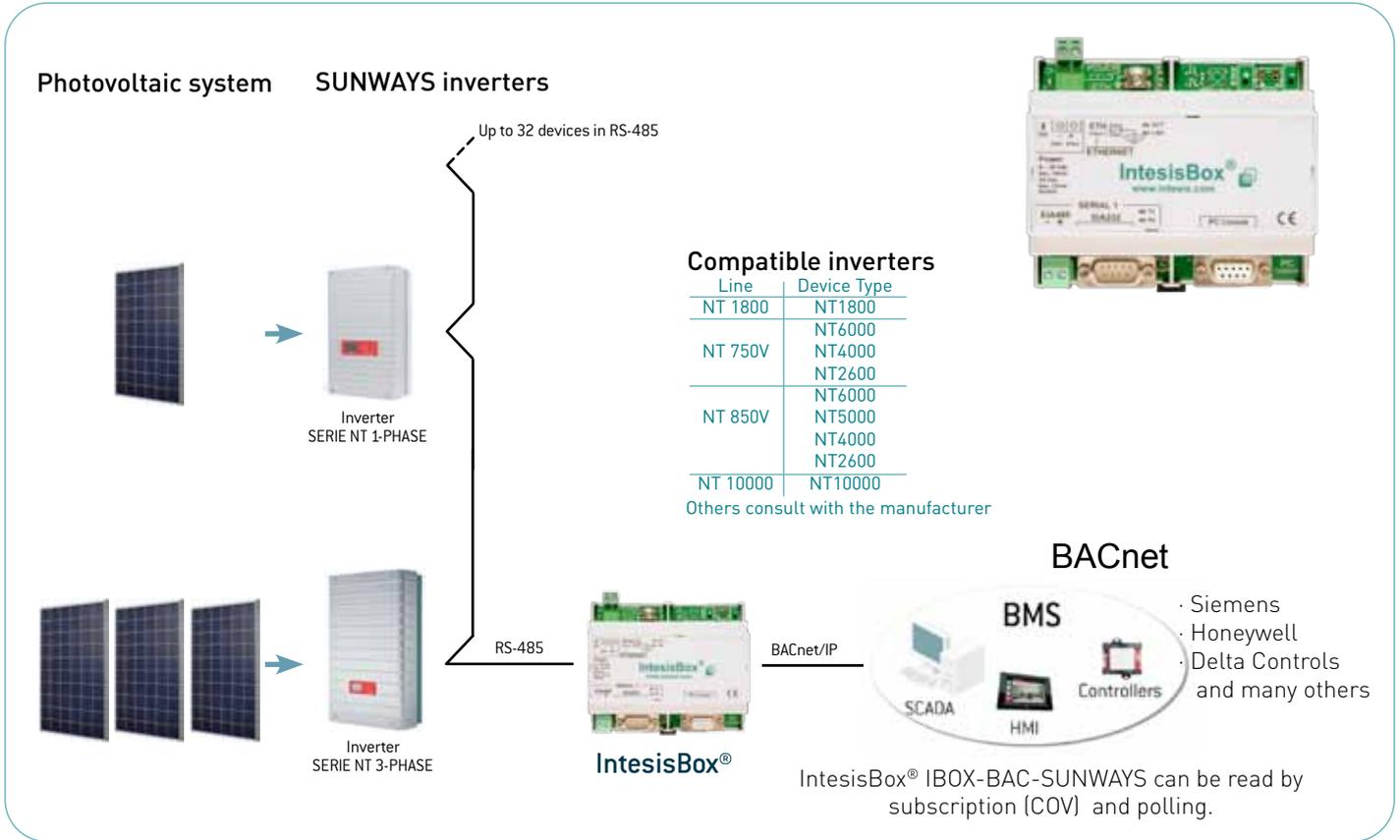

Specifications

- Bidirectional: Monitoring and Control
- Robust and reliable hardware
- Direct connection to RS485 and BACnet/IP
- Independent management of communications
- Power supply: 9 to 24Vdc or 24Vac
- Standard DIN-Rail 6 modules enclosure

Main features

- Easy installation. Direct connection using 2 wires (RS485) to SUNWAYS devices.
- Great integration flexibility. IntesisBox® SUNWAYS reads continuously by polling SUNWAYS devices making read values available when needed by polling or subscription (COV). IBOX-BAC-SUNWAYS shows SUNWAYS devices as BACnet devices. IntesisBox unit is configured by supplied LinkBoxBac software.
- Advanced integration of the photovoltaic collection system of SUNWAYS in any control system based in BACnet/IP like Siemens, Honeywell, delta Controls, Trend, etc

Info

Datasheet: http://www.intesis.com/pdf/IntesisBox_BACnet_IP_Server_Sunways_datasheet_eng.pdf

IBOX-BAC-NID3000

IntesisBox® IBOX-BAC-NID3000, gateway has been specially designed to offer monitoring and bidirectional control of the operating parameters of Notifier ID3000 and ID3002 Series fire panels from BACnet/IP installations.

Integration example:
Fire panel Notifier ID series with IBOX-BAC-NID3000



Notifier ID3000
Notifier ID3002

RS-232



IntesisBox®

BACnet/IP

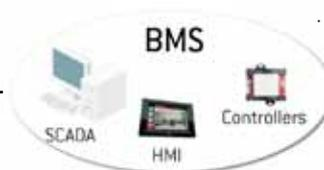

BACnet

- Siemens
- Honeywell
- Delta Controls and many others

IntesisBox® IBOX-BAC-NID3000 can be read by subscription (COV) and polling.

Specifications

- Bidirectional: Monitoring and Control
- Robust and reliable hardware
- Direct connection to RS-232 and BACnet/IP
- Independent management of communications
- Power supply: 9 to 24Vdc or 24Vac
- Standard DIN-Rail 6 modules enclosure

Main features

- Easy installation. Direct connection using a RS-232 cable to main board or optional ISO-RS232 of the fire panel
- Great integration flexibility. IntesisBox® has a fix map of variables allowing a simple integration of the fire panel. All the read values are kept in the IntesisBox® memory to be read by polling or subscription (COV) from the BACnet side. IntesisBox® BACnet server series gateways are configured with the supplied LinkBoxBAC software
- Advanced integration of Notifier fire panels in control systems based in BACnet/IP like Siemens, Honeywell, delta Controls, Trend, etc

Info

Datasheet: http://www.intesis.com/pdf/IntesisBox_BACnet_IP_Server_NID3000_datasheet_eng.pdf



LON



IntesisBox

products for LON systems



LonWorks(local operation network) is a networking platform specifically created to address the needs of control applications. The platform is built on a protocol created by Echelon Corporation for networking devices over media such as twisted pair, powerlines, fiber optics, and RF. It is used for the automation of various functions within buildings such as lighting and HVAC; see Intelligent building. LonWorks technology, an open standard used throughout the world, was developed to solve a problem of traditional control networks — that the nodes that comprised them had to be a-priori designed to work together. The LonWorks platform is used for many diverse applications that span Smart Buildings, Smart Cities, and the Smart Grid.

For further information, please visit
www.echelon.com/technology/lonworks

IntesisBox® Lonworks AC gateways

Specially designed, in collaboration with several manufacturers like Mitsubishi Electric, and Panasonic to allow supervision and bidirectional control of all the parameters and functionality of Air conditioners from Lonworks installations.

- Easy installation to the indoor unit or via dedicated cable or RS232
- Great integration flexibility
- Advanced integration with air conditioner: a complete bidirectional communication and simultaneous control from LON and the infrared Air Conditioner remote controller. Also, a PANURBAN gateway offers a full transparent integration of Panasonic AC installations in BMS systems based in Lonworks Like TAC, Siemens, Honeywell, etc.

IntesisBox LON-KNX gateway

IntesisBox® IBOX-LON-KNX gateway has been specially designed to allow supervision and bidirectional control of KNX systems from LonWorks installations.

- **Easy installation** through KNX TP (TP-1) for KNX devices and FT/TP-10 for Lonworks devices
- **Great integration flexibility.** With the IntesisBox® IBOX-LON-KNX gateway all the KNX installation is seen as a node in the LonWorks® network, with each KNX group address associated to a SNVT field, fully compatible with any standard LonWorks® commissioning tool (LonMaker and others). IntesisBox® LON and KNX interfaces are configured with LinkBoxLON, a Windows® compatible software supplied with the purchase of IntesisBox®
- **Advanced integration with any device.** IntesisBox® IBOX-LON-KNX offers a complete and transparent integration of KNX installations (light control, blinds, ...) in building management systems based in LonWorks® (TAC, Siemens, Honeywell...).

LON

ME-AC-LON-1

IntesisBox® ME-AC-LON-1 gateway has been specially designed, in collaboration with Mitsubishi Electric, to allow monitoring and bidirectional control of all the parameters and functionality of Mitsubishi Electric air conditioners from Lonworks® installations. Compatible with Domestic and Mr. Slim Series manufactured by Mitsubishi Electric.



Specifications

- Bidirectional: Monitoring and Control
- Direct connection to LON bus and to the AC indoor unit
- No external power supply required
- Small size (WxHxD): 93 x 53 x 58 mm.

Main features

- Easy installation inside the AC indoor unit. Cable for CN105 or CN92 connector supplied.
- Great integration flexibility. Monitoring and control from basic parameters to a complete Monitoring and control of the AC units is possible.
- Special communication objects for increasing comfort and energy savings: Open window, Working hours counter, Save /execute scenes, Enable/Disable device, Enable/disable remote controller,...
- Simultaneous control from LON and the Mitsubishi Electric air conditioning IR handset.

Info

Datasheet: http://www.intesis.com/pdf/IntesisBox_ME_AC_LON_1_leaflet_eng.pdf

Compatibility list: http://www.intesis.com/pdf/IntesisBox_ME-AC-xxx-1_AC_Compatibility.pdf

IBOX-LON-PANURBAN

IBOX-LON-PANURBAN gateway has been specially designed, in collaboration with PANASONIC, to allow monitoring and bidirectional control of all the parameters and functionality of PANASONIC air conditioners from Lonworks® installations.

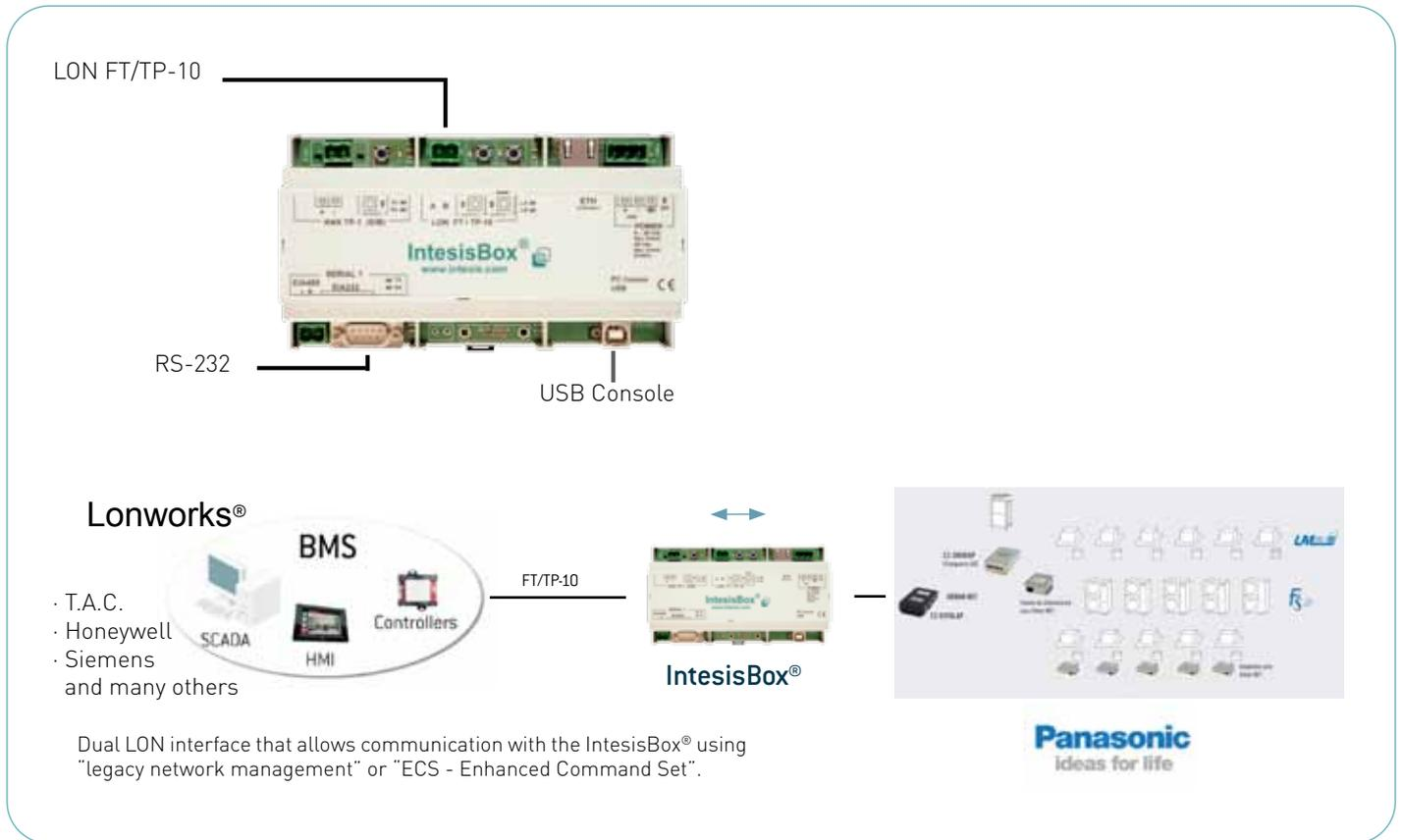

Specifications

- Bidirectional: Monitoring and Control
- Robust and reliable hardware
- Direct connection to LON bus
- Independent management of communications
- Power supply: 9 to 24Vdc or 24Vac
- Standard DIN-Rail 9 modules enclosure

Main features

- Easy installation. Direct connection using a RS-232 cable to the Panasonic CZ-01FULAP device.
- Great integration flexibility. All AC installation appears like a node in the LonWorks network. The gateway includes a LON TP/FT-10 connection. NO configuration required.
- Advanced integration. Offers a full transparent integration of Panasonic AC installations, in BMS systems like TAC, Siemens, Honeywell, etc.

Info

Datasheet: http://www.intesis.com/pdf/IntesisBox_LON_PANURBAN_datasheet_eng.pdf

IBOX-LON-KNX

IntesisBox® IBOX-LON-KNX gateway has been specially designed to allow monitoring and bidirectional control of KNX systems from LonWorks® installations.

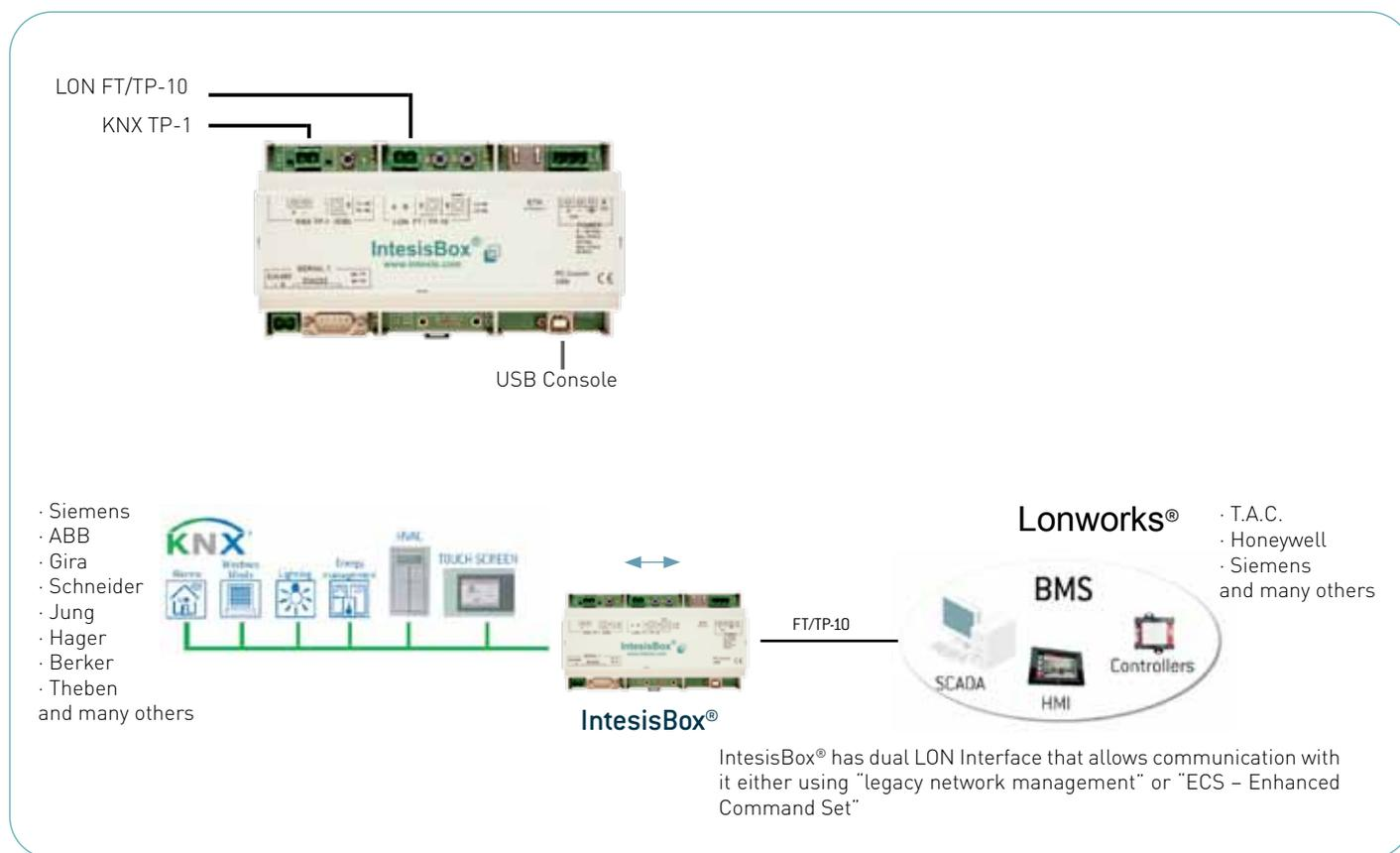

Specifications

- Bidirectional: Monitoring and Control
- Robust and reliable hardware
- Direct connection to KNX and LON bus
- Independent management of communications
- Power supply: 9 to 24Vdc or 24Vac
- Standard DIN-Rail 9 modules enclosure

Models available

- IBOX-LON-KNX-200 (Maximum 200 control points)
- IBOX-LON-KNX-A (Maximum 500 control points)
- IBOX-LON-KNX-B (Maximum 4000 control points)

Info

Datasheet: http://www.intesis.com/pdf/IntesisBox_LON_KNX_datasheet_eng.pdf

Main features

- Easy installation. Direct connection to KNX twisted pair bus (TP-1)
- Great integration flexibility. All KNX installation appears like a node in the LonWorks network. IntesisBox® LON and KNX interfaces configured with LinkBoxLON supplied software. KNX group addresses can be imported from ETS CSV or ESF files.
- Advanced integration of KNX installations (light control, blinds, ...) in BMS systems based in LonWorks (TAC, Siemens, Honeywell ...).





ENOCEAN

IntesisBox

products for EnOcean wireless systems



The EnOcean Alliance is a consortium of companies working to further develop and promote self-powered wireless monitoring and control systems for sustainable buildings by formalising the interoperable wireless standard. The EnOcean Alliance has the largest installed base of field-proven wireless building automation networks in the world. A group of key companies across Europe and North America are currently forming the EnOcean Alliance as a non-profit, mutual benefit corporation which has the formal purpose of:

- establishing energy harvesting wireless technology as the wireless standard for sustainable buildings
- helping to bring about the existence of a broad range of interoperable wireless monitoring and controlling products for use in and around residential, commercial and industrial buildings and to promote global trade in such products
- by initially developing the specifications for the interoperability of the sensor profiles for the wireless products operating in unlicensed frequency bands and subsequently to apply for ratification as an international standard at the appropriate standardization committee .

For further information, please visit www.enocean-alliance.org

EnOcean IntesisBox® AC gateways

Specially designed, in collaboration with several AC manufacturers like Mitsubishi Electric, Daikin and Panasonic to allow supervision and bidirectional control of all the parameters and functionality of Air conditioners from EnOcean installations.

- **Easy installation** to the indoor unit via dedicated cable
- **Great integration flexibility.** To be linked to all kind of sensors, actuators or gateways allowing a full control and supervision from several devices in parallel. The implementation of the newly approved Generic HVAC interface EEP's (along many others) give them even a higher integration to B.M.S. gateways.
- **Configurable advanced room control functionalities.** IntesisBox® EnOcean gateways include specific configurable behaviors when linked to devices such as window contact, key card or presence sensors, allowing an advance control of the AC units and leading to savings in Energy. It can work as an EnOcean repeater too.
- **Virtual temperature functionality.** Specially useful when it is imperative to use an external ambient temperature reference, either from an EnOcean temperature sensor or a thermostat, or when the heating and the air conditioner want to be controlled from the same EnOcean thermostat.

IntesisBox EnOcean gateways for USB enabled devices

This product range includes also other gateways models allowing supervision and bidirectional control of any EnOcean device from PC systems such as SCADA's, control systems based in ASCII protocols, or monitoring B.M.S and USB enabled systems

- **Easy installation.** Plug and Play: IntesisBox® gateways only need to be connected to the USB port of the control system, typically a PC, and they will generate a virtual COM port being ready to be used.
- **Great integration flexibility** Intesisbox gateways can be used with all kind of EnOcean devices such as sensors, actuators or gateways allowing a full control and supervision of these devices.
- **Remote configuration of other Intesisbox® gateways.** Depending on model, it is possible to set up some functionalities of other IntesisBox EnOcean gateways

ME-AC-ENO-1 / ME-AC-ENO-1C

IntesisBox® ME-AC-ENO-1 / 1C gateways have been specially designed, in collaboration with Mitsubishi Electric, to allow monitoring and bidirectional control of all the parameters and functionality of Mitsubishi Electric air conditioners from EnOcean installations. Compatible with all the models of the Domestic and Mr. Slim Series manufactured by Mitsubishi Electric.



Specifications

- Bidirectional: Monitoring and Control
- Multiple EnOcean EEP's supported
- Configurable advanced room control functionalities
- Repeater functionality available
- Direct connection to the AC indoor unit
- No external power supply required
- Small size (WxHxD): 71 x 71 x 27 mm

Models available

- ME-AC-ENO-1 (EnOcean freq: 868 MHz. Europe)
- ME-AC-ENO-1C (EnOcean freq: 315 MHz. USA and Asia)

** For other world locations contact your supplier

Info

Datasheet: http://www.intesis.com/pdf/IntesisBox_ME-AC-ENO-1_datasheet_eng.pdf

Compatibility list: http://www.intesis.com/pdf/IntesisBox_ME-AC-xxx-1_AC_Compatibility.pdf

Main features

- Easy installation. Direct connection to the AC indoor unit (CN105 or CN92 connector). Cable supplied.
- Great integration flexibility for all kind of EnOcean enabled sensors, actuators or gateways
- Configurable advanced room control functionalities using IS-ENO-MANAGER software. It can work as a repeater.
- Virtual temperature functionality. Useful when an external ambient temperature reference is required.
- Simultaneous control from EnOcean devices and the Air Conditioner IR handset.

MH-RC-ENO-1i / MH-RC-ENO -1iC

IntesisBox® MH-RC-ENO-1i allows monitoring and bidirectional control of all the operational parameters of Mitsubishi Heavy Industries air conditioners from EnOcean installations. Compatible with FD, KX6 and KXR6 Series manufactured by Mitsubishi Heavy Industries. 4 free-use binary inputs.

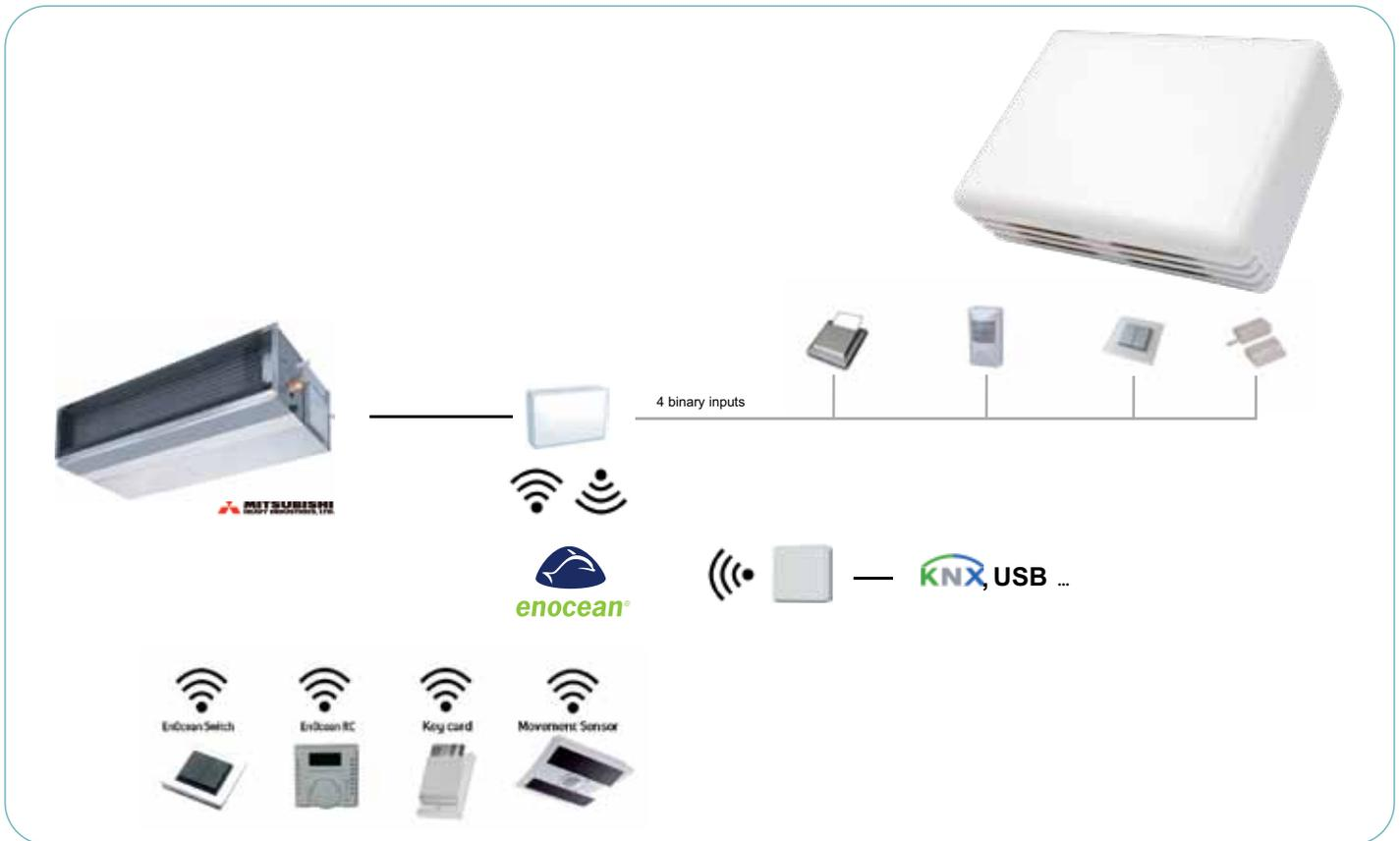

Specifications

- Bidirectional: Monitoring and Control
- Multiple EnOcean EEP's supported
- Configurable advanced room control functionalities
- Direct connection to the AC indoor unit.
- 4 binary inputs.
- No external power supply required
- Small size (WxHxD): 70 x 100 x 28 mm

Models available

- MH-RC-ENO-1i: working at 868 MHz (Europe)
- MH-RC-ENO-1iC: working at 315 MHz (USA and Asia)

** For other world locations contact your supplier

Info

Datasheet: http://www.intesis.com/pdf/IntesisBox_MH-RC-ENO-1i_datasheet_eng.pdf

Main features

- Easy installation. Direct connection to the AC unit by X/Y bus (2 wire). Up to 16 AC indoor units can be connected to IntesisBox®, controlling them as one (not individually).
- Great integration flexibility for all kind of EnOcean enabled sensors, actuators or gateways. Configurable advanced room control functionalities using the IS-ENO-MANAGER software.
- 4 binary inputs working as standard EnOcean inputs or directly controlling the AC unit
- Virtual temperature functionality. Useful when an external ambient temperature reference is required.
- Simultaneous control from EnOcean devices and the Air Conditioner remote controller.

DK-AC-ENO-1 / DK-AC-ENO-1C

IntesisBox® DK-AC-ENO-1 / 1C gateways have been specially designed, in collaboration with Daikin, to allow monitoring and bidirectional control of all the parameters and functionality of Mitsubishi Electric air conditioners from EnOcean installations. Compatible with all the models of the Domestic Series manufactured by DAIKIN.



Specifications

- Bidirectional: Monitoring and Control
- Multiple EnOcean EEP's supported
- Configurable advanced room control functionalities
- Repeater functionality available
- Direct connection to the AC indoor unit
- No external power supply required
- Small size (WxHxD): 71 x 71 x 27 mm

Models available

- DK-AC-ENO-1 (EnOcean Freq: 868 MHz. Europe)
- DK-AC-ENO-1C (EnOcean Freq: 315 MHz. USA and Asia)

** For other world locations contact your supplier

Main features

- Easy installation. Direct connection to the AC indoor unit [S21 connector]. Cable supplied.
- Great integration flexibility for all kind of EnOcean enabled sensors, actuators or gateways
- Configurable advanced room control functionalities using the IS-ENO-MANAGER software. Can work as repeater.
- Virtual temperature functionality. Useful when an external ambient temperature reference is required.
- Simultaneous control from EnOcean devices and the Air Conditioner IR handset.

Info

Datasheet: http://www.intesis.com/pdf/IntesisBox_DK-AC-ENO-1_datasheet_eng.pdf

Compatibility list: http://www.intesis.com/pdf/IntesisBox_DK-AC-xxx-1_AC_Compatibility.pdf

DK-RC-ENO-1i / DK-RC-ENO-1iC

IntesisBox® DK-RC-ENO-1i allows Monitoring and control, fully bi-directionally, of all the operational parameters of DAIKIN Sky & VRV Air Conditioners from EnOcean installations. 4 free-use binary inputs.

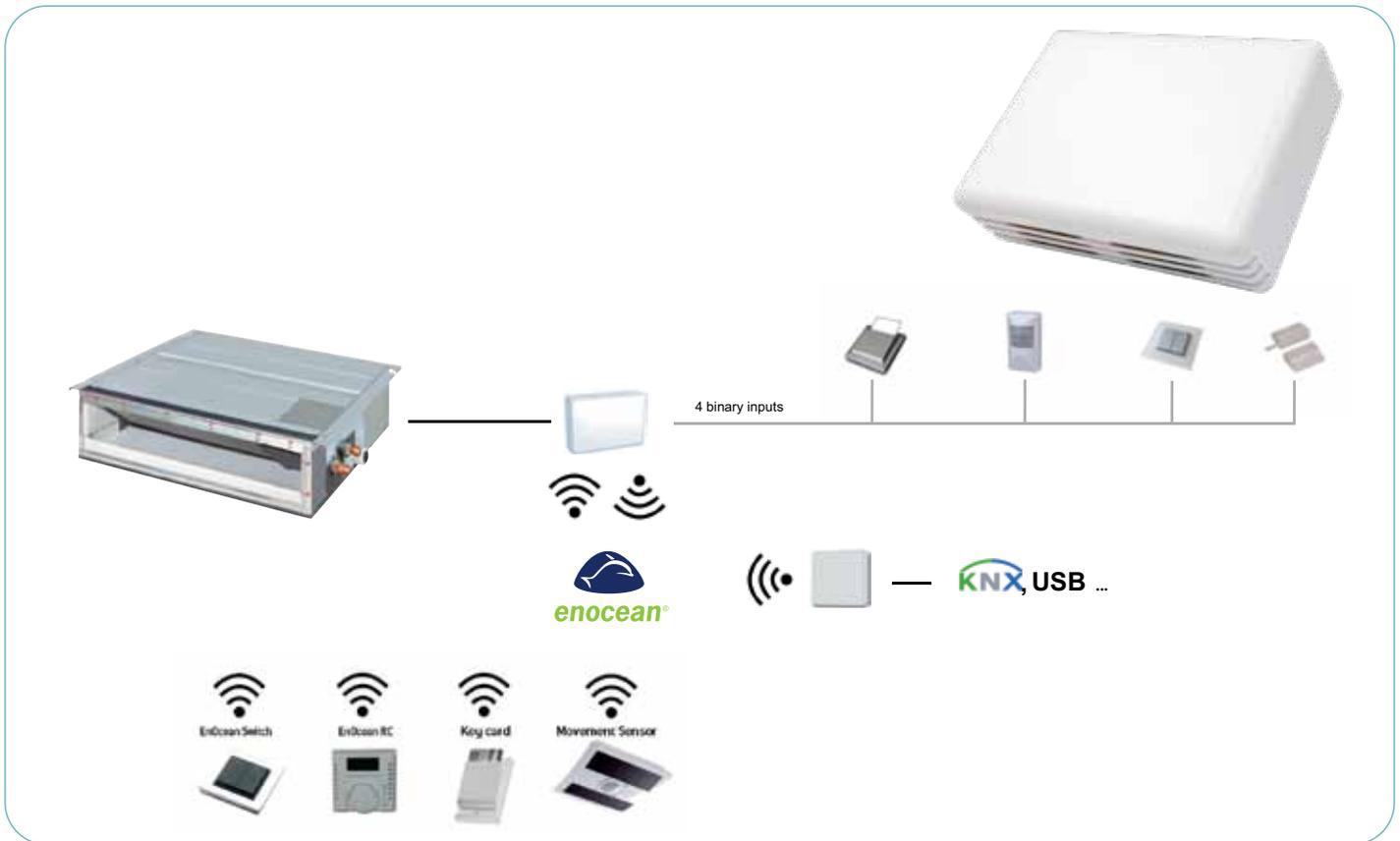

Specifications

- Bidirectional: Monitoring and Control
- Configurable advanced room control functionalities
- Repeater functionality available
- 4 potential free binary inputs
- No external power supply required
- Small size (WxHxD): 70 x 100 x 28 mm

Models available

- DK-RC-ENO-1i (EnOcean Freq: 868 MHz. Europe)
- DK-RC-ENO-1iC (EnOcean Freq: 315 MHz. USA and Asia)

** For other world locations contact your supplier

Info

Datasheet: http://www.intesis.com/pdf/IntesisBox_DK-RC-ENO-1i_datasheet_eng.pdf

Compatibility list: http://www.intesis.com/pdf/IntesisBox_DK-RC-xxx-1_AC_Compatibility.pdf

Main features

- Easy installation as Slave or Master in parallel with Daikin remote controllers.
- Great integration flexibility for all kind of EnOcean enabled sensors, actuators or gateways. 4 binary inputs working as standard EnOcean inputs or directly controlling the AC unit
- Configurable advanced room control functionalities using the IS-ENO-MANAGER software. Can work as repeater.
- Virtual temperature functionality. Useful when an external ambient temperature reference is required.

PA-AC-ENO-1i / PA-AC-ENO-1iC

IntesisBox® PA-AC-ENO-1i allows monitoring and control, fully bi-directionally, of all the operational parameters of PANASONIC air conditioners from EnOcean installations. Compatible with Etherea MKE and NKE Series manufactured by PANASONIC. 4 free-use binary inputs.



Specifications

- Bidirectional: Monitoring and Control
- Configurable advanced room control functionalities
- Repeater functionality available
- 4 potential free binary inputs
- No external power supply required
- Small size (WxHxD): 70 x 100 x 28 mm

Models available

- PA-AC-ENO-1i (EnOcean freq: 868 MHz. Europe)
- PA-AC-ENO-1iC (EnOcean freq: 315 MHz. USA and Asia)

** For other world locations contact your supplier

Main features

- Easy installation. Direct connection to the AC indoor unit (Etherea Series CN-CNT connector). Cable supplied.
- Great integration flexibility for all kind of EnOcean sensors, actuators or gateways.
- 4 binary inputs working as standard EnOcean inputs or directly controlling the AC unit
- Configurable advanced room control functionalities using the IS-ENO-MANAGER software. Can work as repeater.
- Virtual temperature functionality. Useful when an external ambient temperature reference is required.

Info

Datasheet: http://www.intesis.com/pdf/IntesisBox_PA-AC-ENO-1i_datasheet_eng.pdf

Compatibility list: http://www.intesis.com/pdf/IntesisBox_PA-AC-xxx-1_AC_Compatibility.pdf

USB-ENO / USB-ENO-C

IntesisBox® USB-ENO / C gateways allow monitoring and bidirectional control of any EnOcean device in your USB enabled controller or PC software.



Integration example:
Standard EnOcean devices controlled or supervised from an EnOcean PC software (SCADA, ...)

EnOcean Devices

Switches

- Wireless Switches
- Key card readers
- Window contacts
- Industrial switches

Sensors

- Temperature Sensors
- Humidity Sensors
- Movement Sensors
- Luminance Sensors

Automatization

- Air Conditioners
- Actuators
- Room controllers and many others



Specifications

- Bidirectional: Monitoring and Control
- Unlimited quantity of transmitters supported
- Up to 128 actuators
- ESP2 and ESP3 Compatible
- Repeater functionality available
- USB Powered. No external power supply needed

Models available

- USB-ENO (EnOcean Freq: 868 MHz. Europe)
- USB-ENO-C (EnOcean Freq: 315 MHz. USA and Asia)

** For other world locations contact your supplier

Info

Datasheet: http://www.intesis.com/pdf/IntesisBox_USB-ENO_datasheet_eng.pdf

Main features

- Easy installation. Plug & Play. Direct connection to the USB port of the control system. A virtual COM port is generated.
- Great integration flexibility for all kind of EnOcean sensors, actuators or gateways. Can work as level 1 or 2 repeater enabling EnOcean network expansion.
- Remote management of other IntesisBox gateways. Using IS-ENO-MANAGER-A1 software.

USB-ENO-ASCII / USB-ENO-ASCII-C

IntesisBox® USB-ENO-ASCII / C gateways allow monitoring and bidirectional control of any IntesisBox® EnOcean AC gateway for air conditioners in your USB enabled controller or PC software using simple text (ASCII) messages.



Integration example:
EnOcean AC gateways controlled and supervised from a PC software (SCADA, ...)



Specifications

- Bidirectional: Monitoring and Control
- Up to 10 AC gateways
- Fast and Easy commissioning
- USB Powered. No external power supply needed
- Small size (WxHxD): 71 x 71 x 27 mm

Models available

- USB-ENO-ASCII (EnOcean Freq: 868 MHz. Europe)
- USB-ENO-ASCII-C (EnOcean Freq: 315 MHz. USA and Asia)

** For other world locations contact your supplier

Main features

- Easy installation. Plug & Play. Directo connection to the USB port of the control system. A virtual COM port is generated.
- Great integration flexibility. Full control and Monitoring of AC units trough ASCII commands. Ideal solution for existing systems. Uses RS-232 communication. Spontaneous messages to be sent when AC variables are changed, avoiding to perform continuous polling.
- Remote configuration of the AC gateway working parameters

Info

Datasheet: http://www.intesis.com/pdf/IntesisBox_USB-ENO-ASCII_datasheet_eng.pdf

USB-ENO-ASCII-U / USB-ENO-ASCII-U-C

IntesisBox® USB-ENO-ASCII-U / C gateways allow monitoring and bidirectional control of any Intesisbox® EnOcean device in your USB enabled controller or PC software using simple text (ASCII) messages.

Integration example:
Standard EnOcean devices controlled or supervised from PC software (SCADA, ...)



EnOcean Devices

Switches

- Wireless Switches
- Key card readers
- Window contacts
- Industrial switches

Sensors

- Temperature Sensors
- Humidity Sensors
- Movement Sensors
- Luminance Sensors

Automatization

- Air Conditioners
- Actuators
- Room controllers and many others



Specifications

- Bidirectional: Monitoring and Control
- Up to 128 transmission channels supported
- Up to 99 receive channels supported
- Repeater functionality available
- USB Powered. No external power supply needed
- Small size (WxHxD): 71 x 71 x 27 mm

Models available

- USB-ENO-ASCII-U (EnOcean Freq: 868 MHz. Europe)
- USB-ENO-ASCII-U-C (EnOcean Freq: 315 MHz. USA and Asia)

** For other world locations contact your supplier

Info

Datasheet: http://www.intesis.com/pdf/IntesisBox_USB-ENO-ASCII-U_datasheet_eng.pdf

Main features

- Easy installation. Plug & Play. Directo connection to the USB port of the control system. A virtual COM port is generated.
- Great integration flexibility. To be used with EnOcean sensors, actuators or gateways. Spontaneous messages to be sent when AC variables are changed, avoiding to perform continuous polling. Device configuration with ASCII commands. Can work as level 1 or 2 repeater enabling EnOcean network expansion.
- Advanced integration. Full and transparent integration of EnOcean installations (control of air conditioners, lights, blinds...) in ASCII based BMS installations.

IS-TK04

The IntesisBox® IS-TK04 range of Room Temperature Sensor and controllers allow the control of the EnOcean Air conditioner gateways as well as other climate devices.



Main features

- Transmission only
- Powered by solar cell
- EEPs: 07-02-05, 07-10-01 & 07-10-02, 07-10-03, 07-10-05 & 07-10-06
- Small size (WxHxD): 84.5 x 84.5 x 25 mm

Models available

IS-TK04 Room temperature sensor
IS-TK04P Room temperature sensor with set point adjustment
IS-TK04PT Room temperature sensor with set point adjustment, presence key
IS-TK04P MS Room temperature sensor with set point adjustment, Slide switch 0/I
IS-TK04PST Room temperature sensor with set point adjustment, presence key, fan speed switch
IS-TK04PS MS Room temperature sensor with set point adjustment, Slide switch 0/I, fan speed switch

For devices working at 315Mhz add «-C» to the reference

Info

http://www.intesis.com/pdf/IntesisBox_IS-TK04_datasheet.pdf

IS-TK65

The IntesisBox® IS-TK04 is an outdoor temperature sensor.



Main features

- Transmission only
- Powered by solar cell
- Measured temperature: -20...60°C

Models available

IS-TK65 Outdoor temperature sensor at 868 MHz
IS-TK65-C Outdoor temperature sensor at 315 MHz

Info

http://www.intesis.com/pdf/IntesisBox_IS-TK65_datasheet.pdf





ASCII

IBOX-ASCII-KNX

IntesisBox® IBOX-ASCII-KNX gateway has been specially designed to allow monitoring and bidirectional control of KNX systems using simple text (ASCII) messages.

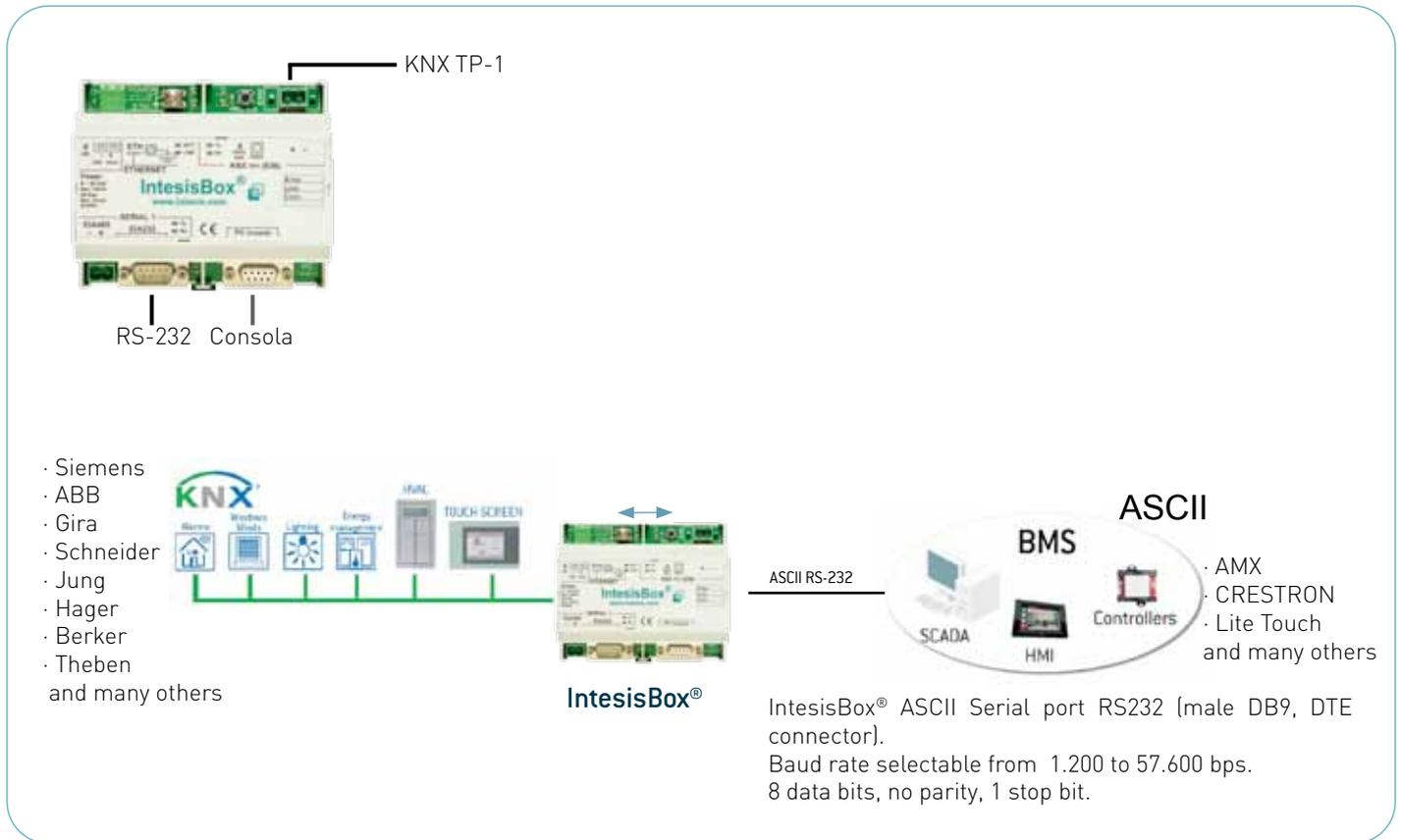

Specifications

- Bidirectional: Monitoring and Control
- Robust and reliable hardware
- Direct connection to KNX
- Independent management of communications
- Power supply: 9 to 24Vdc or 24Vac
- Standard DIN-Rail 6 modules enclosure

Models available

- IBOX-ASCII-KNX (Maximum 4000 control points)

Main features

- Easy installation. Direct connection to KNX twisted pair bus (TP-1).
- Great integration flexibility. The gateway becomes another device in KNX system. A mirror of KNX points values is kept ready to serve the ASCII system. Configuration with supplied software LinkBoxEIB. KNX variables read/written by text messages.
- Complete and transparent integration of KNX installations (light control, blinds, ...) in programmable control systems using simple text messages through RS232 serial protocol [AMX, Crestron, Lite Touch,...].

Info

Datasheet: http://www.intesis.com/pdf/IntesisBox_ASCII_Server_KNX_datasheet_eng.pdf

IBOX-ASCII-LON

IntesisBox® IBOX-ASCII-LON gateway has been specially designed to allow monitoring and bidirectional control of LON systems using simple text (ASCII) messages.

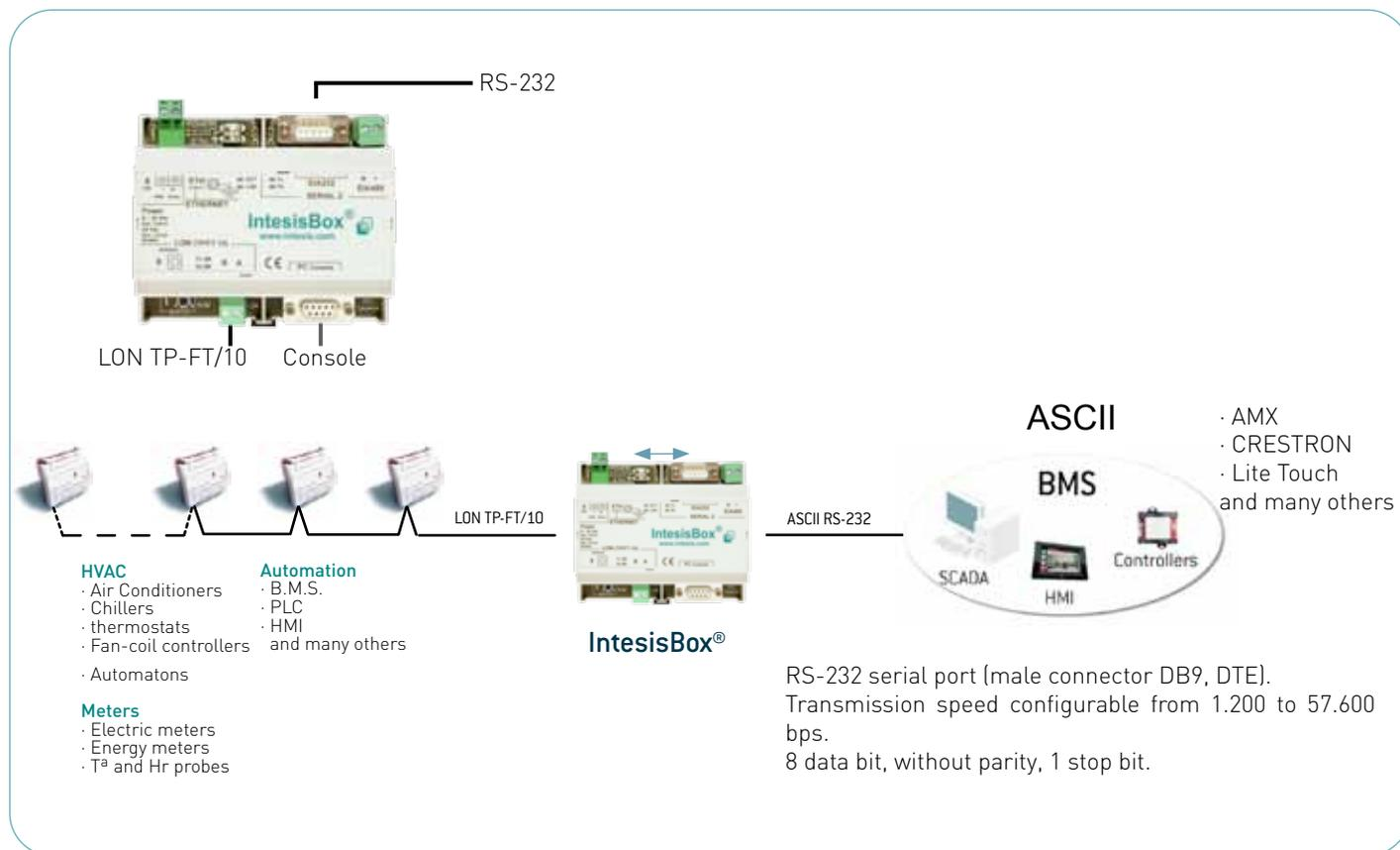

Specifications

- Bidirectional: Monitoring and Control
- Robust and reliable hardware
- Direct connection to LON
- Independent management of communications
- Power supply: 9 to 24Vdc or 24Vac
- Standard DIN-Rail 6 modules enclosure

Models available

- IBOX-ASCII-LON-A (Maximum 500 control points and 64 LON devices)
- IBOX-ASCII-LON-B (Maximum 4000 control points and 128 LON devices)

Info

Datasheet: http://www.intesis.com/pdf/IntesisBox_ASCII_Server_LON_datasheet_eng.pdf

Main features

- Easy installation. Direct connection using 2 cable (TP-FT/10) to LON devices.
- Great integration flexibility. Thanks to LinkBoxASCII supplied software. No bindings needed thanks to continuous polling readout. Access through physical address (Neuron-Id) or subnet node (commissioned devices) possible. LonMaker not required. Configuration using supplied LinkBoxASCII. RS-232 serial communication. LON variables can be read/write easily from the ASCII side, using simple text messages.
- Complete and transparent integration of LON installations (light control, blinds, ...) in programmable control systems using simple text messages through RS232 serial protocol (AMX, Crestron, Lite Touch,...).

IBOX-ASCII-BAC

IntesisBox® IBOX-ASCII-BAC gateway have been specially designed to allow monitoring and bidirectional control of BACnet/IP systems using simple text (ASCII) messages.

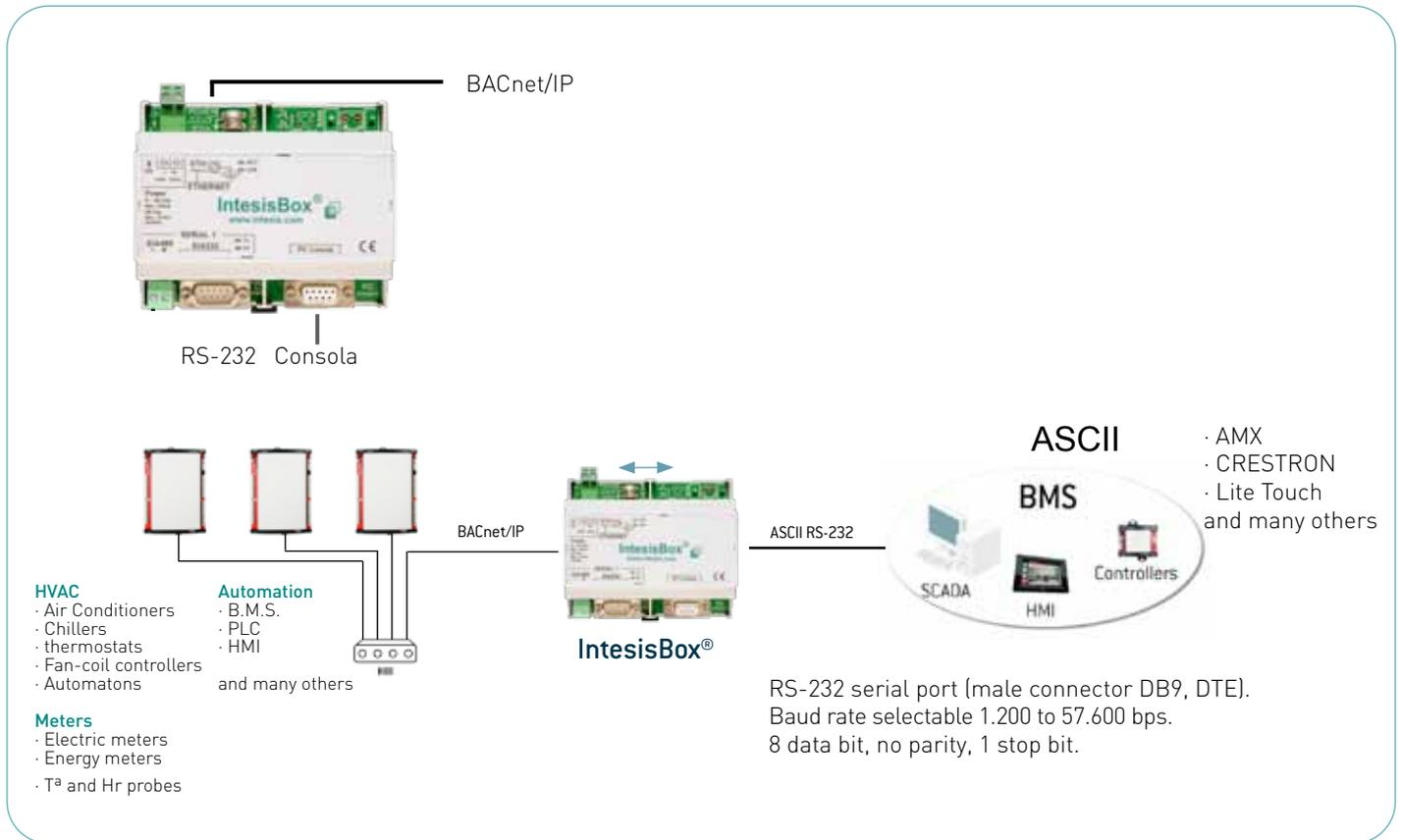

Specifications

- Bidirectional: Monitoring and Control
- Robust and reliable hardware
- Direct connection to BACnet/IP network
- Independent management of communications
- Power supply: 9 to 24Vdc or 24Vac
- Standard DIN-Rail 6 modules enclosure

Models available

- IBOX-ASCII-BAC-A (Maximum 500 control points and 64 BACnet/IP devices)
- IBOX-ASCII-BAC-B (Maximum 4000 control points and 64 BACnet/IP devices)

Info

Datasheet: http://www.intesis.com/pdf/IntesisBox_ASCII_Server_Bacnet_IP_Client_datasheet_eng.pdf

Main features

- Easy installation.
- Great integration flexibility. The IntesisBox gateway can read other BACnet devices using continuous polling or subscription (COV). BACnet/IP objects can be read/write easily from the ASCII side, using simple text messages. Spontaneous messages can be sent to ASCII side when value changes are detected, avoiding to perform continuous polling. Configured by supplied software LinkBoxBAC.
- Advanced integration. Full transparent integration of BACnet devices in BMS systems based in ASCII like AMX, Crestron, Lite Touch, etc.

OPC



Intesis OPC Servers

Intesis OPC Servers have been specially designed to offer monitoring of fire panels from Scada systems with OPC Client driver.

Intesis OPC Server	Panel manufacturer	Panel models
IS-OPC-NID3K	NOTIFIER	ID3000, ID3002, ID50, ID60 in ID2net network
IS-OPC-ESSER	ESSER	8007/8008 and IQ8

Intesis OPC Server	Datasheet download
IS-OPC-NID3K	http://www.intesis.com/pdf/Intesis_OP_C_Ser_NID3000_datasheet_eng.pdf
IS-OPC-ESSER	http://www.intesis.com/pdf/Intesis_OP_C_Ser_Esser_datasheet_eng.pdf

Integration example:
Fire panel Notifier with IS-OPC-NID3K



Notifier ID3000
Notifier ID3002
Notifier ID50
Notifier ID60

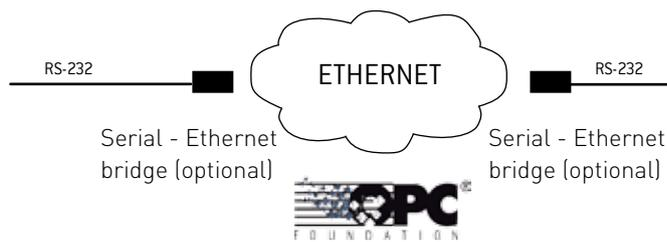

- Wonderware
- Intellution
- ABB
- and many others

Notes

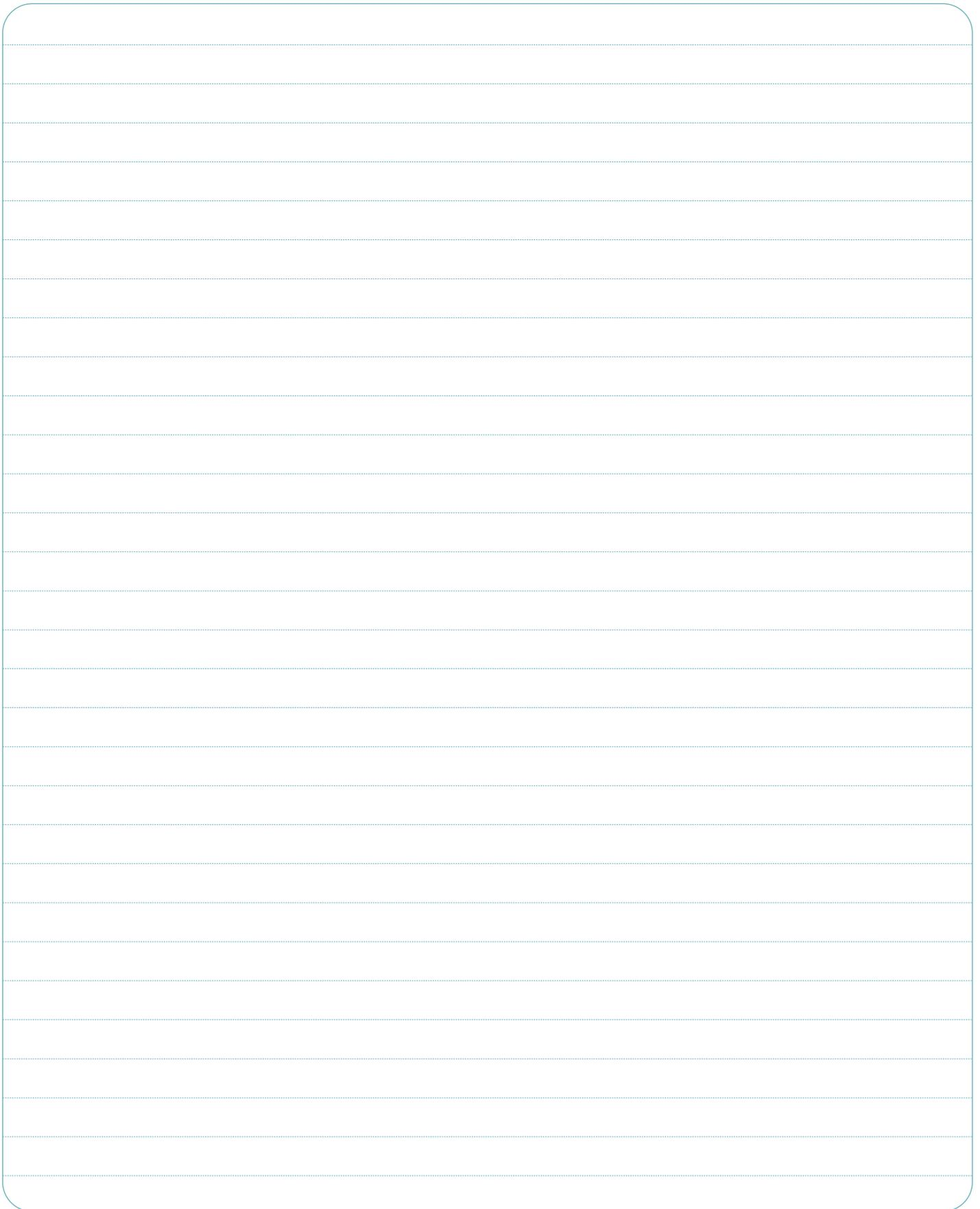



Notes

A large rectangular area with rounded corners, containing horizontal dashed lines for writing notes.

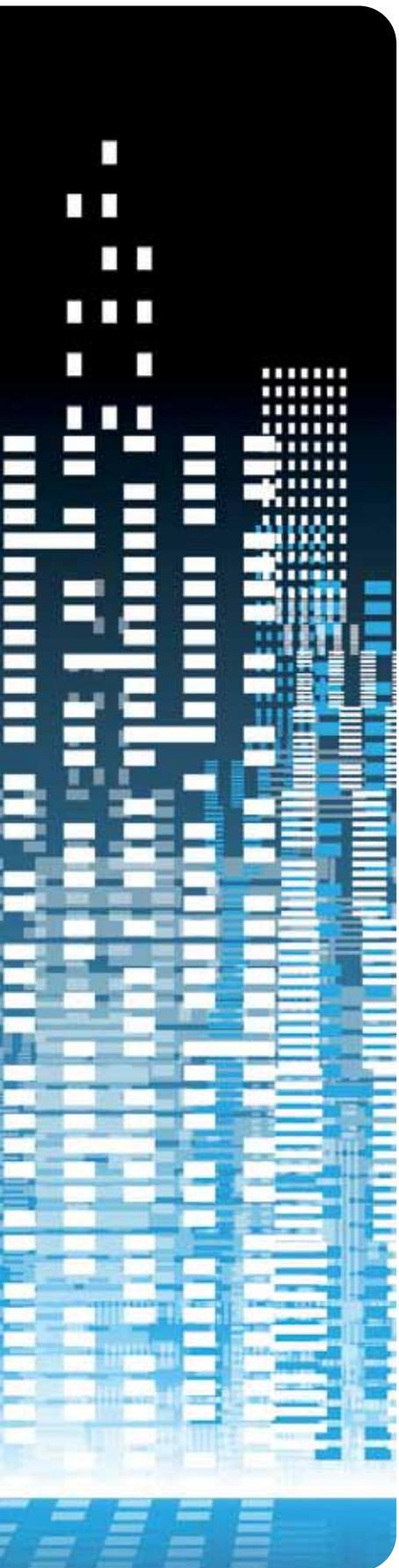

Intesis

your partner for **systems integration**



C/ Milà i Fontanals, 1 bis 1º. 08700 Igualada · Barcelona · Spain
Tel. +34 93 804 71 34 · Fax. +34 93 804 71 35 · sales@intesis.com

www.intesis.com

IntesisBox® 

Authorized Dealer



Intesis Software is member of the KNX Association , KNX Spain and EnOcean Alliance

